



ShadowRib™

Technical/Installation Information

IMPORTANT NOTICE

READ THIS MANUAL COMPLETELY PRIOR TO BEGINNING THE INSTALLATION OF THE ShadowRib™ ROOFING SYSTEM. THE MANUFACTURER DETAILS MUST BE FOLLOWED AS A MINIMUM TO INSURE APPROPRIATE WARRANTIES WILL BE ISSUED.

ALWAYS INSPECT EACH AND EVERY PANEL AND ALL ACCESSORIES BEFORE INSTALLATION. NEVER INSTALL ANY PRODUCT IF ITS QUALITY IS IN QUESTION. NOTIFY MBCI IMMEDIATELY IF ANY PRODUCT IS BELIEVED TO BE OUT OF TOLERANCE, SPECIFICATION OR HAS BEEN DAMAGED DURING SHIPMENT.

IF THERE IS A CONFLICT BETWEEN PROJECT INSTALLATION DRAWINGS PROVIDED OR APPROVED BY THE MANUFACTURER AND DETAILS IN THIS MANUAL, PROJECT INSTALLATION DRAWINGS WILL TAKE PRECEDENCE.

©Copyright NCI Group, Inc. All Rights Reserved. 03-2014

The Engineering data contained herein is for the expressed use of customers and design professionals. Along with this data, it is recommended that the design professional have a copy of the most current version of the North American Specification for the Design of Cold-Formed Steel Structural Members published by the American Iron and Steel Institute to facilitate design. This Specification contains the design criteria for cold-formed steel components. Along with the Specification, the designer should reference the most current building code applicable to the project jobsite in order to determine environmental loads. If further information or guidance regarding cold-formed design practices is desired, please contact the manufacturer.

Descriptions and specifications contained herein were in effect at the time this publication was approved for printing. In a continuing effort to refine and improve products, MBCI reserves the right to discontinue products at any time or change specifications and/or designs without incurring obligations. To insure you have the latest information available, please inquire or visit our Website at www.mbc.com. Application details are for illustration purposes only and may not be appropriate for all environmental conditions, building designs, or panel profiles. Projects should be engineered to conform to applicable building codes, regulations, and accepted industry practices. Insulation is not shown in these details for clarity.

For complete performance specifications, product limitations, and disclaimers, please consult MBCI's Paint and Galvalume Plus® warranties. Upon receipt of payment in full, these warranties are available upon request for all painted or Galvalume Plus® prime products. Sample copies can be found at www.mbc.com or contact your local MBCI Sales Representative.

Houston, TX 877/713-6224
Adel, GA 888/446-6224
Atlanta, GA 877/512-6224
Atwater, CA 800/829-9324
Dallas, TX 800/653-6224
Indianapolis, IN 800/735-6224
Jackson, MS 800/622-4136

Las Vegas, NV 877/713-6224
Lewisville, TX 877/713-6224
Lubbock, TX 800/758-6224
Mattoon, IL 888/885-0468
Memphis, TN 800/206-6224
Oklahoma City, OK 800/597-6224
Omaha, NE 800/458-6224

Phoenix, AZ 888/533-6224
Richmond, VA 800/729-6224
Rome, NY 800/559-6224
Salt Lake City, UT 800/874-2404
San Antonio, TX 800/598-6224



TABLE OF CONTENTS

A. General Description	SR-2
B. Architect/Engineer Information	SR-3
C. 16" Properties/Load Tables	SR-4 - 5
D. Specifications	SR-6-10
E. Product Checklist	SR-11-13
F. Installation Guidelines	SR-14
G. Unloading	SR-15-16
H. Handling & Panel Storage	SR-17
I. Panel Attachment Methods	
1. Interior Fastener Attachment	SR-18
2. Exterior Clip Attachment	SR-18-19
J. Clip Angle Attachment	
1. Base	
a. Standard	SR-20
b. Alternate	SR-20
2. Girt	SR-20
3. Eave	SR-21
4. Rake	SR-21
K. Eave Details	
1. Gutter	SR-22
2. Eave Trim	SR-22
L. Rake Details	SR-23
M. Corner Installation	
1. Outside Corner	
a. Finish In High	SR-24
b. Finish In Low	SR-24
2. Inside Corner	
a. Finish In High	SR-25
b. Finish In Low	SR-25
N. Framing Options	
1. Overhead Doors	SR-26
2. Walk Doors	SR-27
3. Windows	SR-28-29
O. Wall Splice	SR-30



Metal Roof and Wall Systems

Houston, TX 877/713-6224
 Adel, GA 888/446-6224
 Atlanta, GA 877/512-6224
 Atwater, CA 800/829-9324
 Dallas, TX 800/653-6224
 Indianapolis, IN 800/735-6224
 Jackson, MS 800/622-4136

Las Vegas, NV 877/713-6224
 Lewisville, TX 877/713-6224
 Lubbock, TX 800/758-6224
 Mattoon, IL 888/885-0468
 Memphis, TN 800/206-6224
 Oklahoma City, OK 800/597-6224
 Omaha, NE 800/458-6224

Phoenix, AZ 888/533-6224
 Richmond, VA 800/729-6224
 Rome, NY 800/559-6224
 Salt Lake City, UT 800/874-2404
 San Antonio, TX 800/598-6224

PRODUCT INFORMATION

ShadowRib™

GENERAL DESCRIPTION

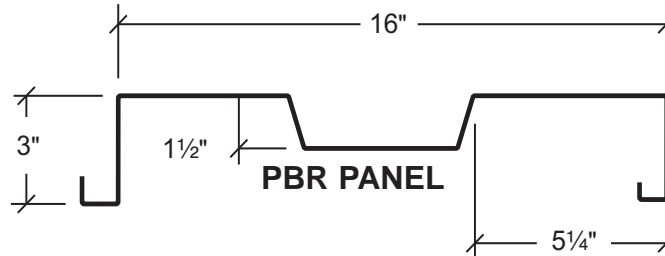

Coverage - 16"

Panel Depth - 3"

Outside Panel Attachment - **ShadowRib™** Panel Clip

Inside Panel Attachment - Fastener #23

Substrate - Galvalume® (Standard)

Gauge - 24 Gauge (Standard) 22 Gauge (Optional)

Coatings - Signature® 200, Signature® 300 and Signature® 300 Metallic.

Check Product Selection Chart below for specific coatings and gauges.

Finish - Smooth (Standard) Embossed (Optional)

PRODUCT SELECTION CHART

PRODUCT	SIGNATURE® 300 METALLIC		SIGNATURE® 300*		SIGNATURE® 200*		SIGNATURE® 200*	
	24 Ga.	22 Ga.	24 Ga.	22 Ga.	24 Ga.	22 Ga.	24 Ga.	22 Ga.
ShadowRib™ 16" Wide	●	■	●	■	●	■	●	■

Signature is a registered trademark of NCI Group INC. Galvalume Plus is a registered and protected trademark of BIEC International, Inc.
 ❖ The Galvalume Plus® coating is subject to variances in spangle from coil to coil which may result in noticeable shade variation in installed panels. The Galvalume Plus® coating is also subject to differential weathering after panel installation. Panels may appear to be different shades due to this weathering characteristic. If a consistent appearance is required, MBCI recommends that pre-painted panels be used in lieu of Galvalume Plus®. Shade variation in panels manufactured from Galvalume Plus® coated material do not diminish the structural integrity of the product. These shade variations should be anticipated and are not a cause for rejection.

- - Available in any quantity.
 - - Minimum quantity may be required.
- *See Commercial/Industrial color chart for available colors.

ShadowRib™ PRODUCT INFORMATION

ARCHITECT/ENGINEER INFORMATION

1. ShadowRib™ is a concealed fastener panel designed to provide an appealing shadow effect on walls, facades or equipment screens. The ShadowRib™ system is based on a 16" module. Therefore, a panel layout for each wall should be provided to ensure that all framed openings begin and end in the "high" of the panel.
2. There are two methods of attachment to the substructure:
 - a. Outside attachment, using a panel clip.
 - b. Inside attachment, using a Fab-Lok Fastener (Fastener #23).
3. All primary and secondary framing must be erected, plumbed and squared with bolts tightened according to accepted building practices prior to beginning the installation of the ShadowRib™ panel.
4. Wall girts, or structurals to which the ShadowRib™ panels are to be attached, must be properly aligned. Structural members that are not in alignment will induce stress into the panels resulting in oil canning.
5. Heavier gauges and embossing minimizes oil canning. The industry standard for this product is 22 and 24 gauge material. Oil canning is not cause for rejection.
6. Panels may be spliced using MBCI'S splice trim. For continuous runs over 40', please inquire.
7. Panel joints may be made airtight and water tight by field applying urethane sealant to the sidelap before engaging panels.
8. All details and recommendations in this manual are for general guidelines only. Actual project conditions may require special treatment and/or changes in this information. Contact MBCI regarding deviations from the published standards. Suitability of use and manner of use of any product contained herein is the sole responsibility of the specifier.
9. Insulation is most effectively applied in the wall cavity behind the point of panel attachment. Semi-rigid or rigid insulation can be inserted in the cavity of the panel between the vertical legs. Applying the panel over compressed blanket insulation can be difficult and may induce waviness or oil canning.

The installation information in this manual typically shows the ShadowRib™ panel being applied over secondary structural framing members. The following chart describes the type of fastener that must be used with alternate structural substrates.

FASTENER APPLICATION CHART

PRODUCT	STRUCTURAL (16 ga. to 12 ga.)	STRUCTURAL (3/8" Maximum)	STRUCTURAL (1/2" Maximum)
ShadowRib™	Fastener #1 or Fastener #23	Fastener #6 or Fastener #23	Fastener #10 or Fastener #23



Metal Roof and Wall Systems

Houston, TX 877/713-6224
 Adel, GA 888/446-6224
 Atlanta, GA 877/512-6224
 Atwater, CA 800/829-9324
 Dallas, TX 800/653-6224
 Indianapolis, IN 800/735-6224
 Jackson, MS 800/622-4136

Las Vegas, NV 877/713-6224
 Lewisville, TX 877/713-6224
 Lubbock, TX 800/758-6224
 Mattoon, IL 888/885-0468
 Memphis, TN 800/206-6224
 Oklahoma City, OK 800/597-6224
 Omaha, NE 800/458-6224

Phoenix, AZ 888/533-6224
 Richmond, VA 800/729-6224
 Rome, NY 800/559-6224
 Salt Lake City, UT 800/874-2404
 San Antonio, TX 800/598-6224

ENGINEERING

ShadowRib™

ShadowRib™

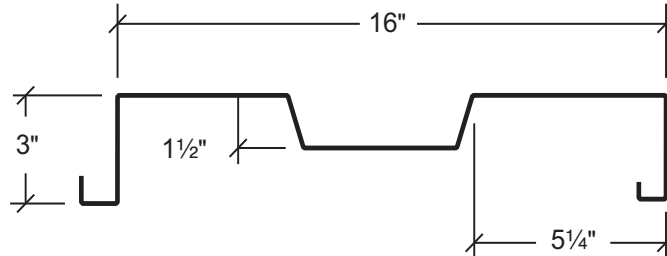

SECTION PROPERTIES								
			NEGATIVE BENDING			POSITIVE BENDING		
PANEL	F _y	WEIGHT	l _{xe}	S _{xe}	Maxo	l _{xe}	S _{xe}	Maxo
GAUGE	(KSI)	(PSF)	(IN.4/FT.)	(IN.3/FT.)	(KIP-IN.)	(IN.4/FT.)	(IN.3/FT.)	(KIP-IN.)
24	50	1.54	0.3497	0.1661	4.972	0.2552	0.1643	4.920
22	50	1.97	0.4892	0.2397	7.176	0.3571	0.2204	6.598

NOTES:

1. All calculations for the properties of ShadowRib Wall panels are calculated in accordance with the 2012 edition of the North American Specification For Design Of Cold-Formed Steel Structural Members.
2. l_{xe} is for deflection determination.
3. S_{xe} is for bending.
4. Maxo is allowable bending moment.
5. All values are for one foot of panel width.

The Engineering data contained herein is for the expressed use of customers and design professionals. Along with this data, it is recommended that the design professional have a copy of the most current version of the *North American Specification for the Design of Cold-Formed Steel Structural Members* published by the American Iron and Steel Institute to facilitate design. This Specification contains the design criteria for cold-formed steel components. Along with the Specification, the designer should reference the most current building code applicable to the project jobsite in order to determine environmental loads. If further information or guidance regarding cold-formed design practices is desired, please contact the manufacturer.

ShadowRib™

SPECIFICATIONS

ShadowRib™

ALLOWABLE UNIFORM LOADS IN POUNDS PER SQUARE FOOT

24 Gauge (0.0223"), Fy = 50 ksi, Fu = 60 ksi								
SPAN TYPE	LOAD TYPE	SPAN IN FEET						
		3.0	4.0	5.0	6.0	7.0	8.0	9.0
1-span	NEGATIVE WIND LOAD	137.04	102.78	82.22	68.52	58.73	51.39	40.93
	LIVE LOAD/DEFLECTION	133.18	99.89	79.91	66.59	57.08	49.94	40.49
2-span	NEGATIVE WIND LOAD	54.82	41.11	32.89	27.41	23.49	20.56	18.27
	LIVE LOAD/DEFLECTION	88.32	66.24	52.99	44.16	37.85	33.12	29.44
3-span	NEGATIVE WIND LOAD	62.29	46.72	37.37	31.15	26.70	23.36	20.76
	LIVE LOAD/DEFLECTION	100.36	75.27	60.22	50.18	43.01	37.63	33.45
4-span	NEGATIVE WIND LOAD	59.95	44.97	35.97	29.98	25.69	22.48	19.98
	LIVE LOAD/DEFLECTION	96.60	72.45	57.96	48.30	41.40	36.22	32.20

22 Gauge (0.0286"), Fy = 50 ksi, Fu = 60 ksi								
SPAN TYPE	LOAD TYPE	SPAN IN FEET						
		3.0	4.0	5.0	6.0	7.0	8.0	9.0
1-span	NEGATIVE WIND LOAD	199.04	149.28	119.42	99.52	85.30	74.64	59.06
	LIVE LOAD/DEFLECTION	212.18	159.14	127.31	106.09	89.77	68.73	54.30
2-span	NEGATIVE WIND LOAD	79.61	59.71	47.77	39.81	34.12	29.86	26.54
	LIVE LOAD/DEFLECTION	140.29	105.22	84.17	70.14	60.12	52.61	46.76
3-span	NEGATIVE WIND LOAD	90.47	67.85	54.28	45.24	38.77	33.93	30.16
	LIVE LOAD/DEFLECTION	159.42	119.56	95.65	79.71	68.32	59.78	53.14
4-span	NEGATIVE WIND LOAD	87.08	65.31	52.25	43.54	37.32	32.65	29.03
	LIVE LOAD/DEFLECTION	153.44	115.08	92.06	76.72	65.76	57.54	51.15

Notes:

- Strength calculations based on the 2012 AISI Standard "North American Specification for the Design of Cold-formed Steel Structural members."
- Allowable loads are applicable for uniform loading and spans without overhangs.
- LIVE LOAD/DEFLECTION load capacities are for those loads that push the panel against its supports. The applicable limit states are flexure, shear, combined shear and flexure, web crippling at end and interior supports, and a deflection limit of L/60 under 10-year wind loading.
- NEGATIVE WIND LOAD capacities are for those loads that pull the panel away from its supports. The applicable limit states are flexure, shear, combined shear and flexure, and a deflection limit of L/60 under 10-year wind loading.
- Panel pullover and Screw pullout capacity must be checked separately using the screws employed for each particular application when utilizing this load chart.
- Effective yield strength has been determined in accordance with section A2.3.2 of the 2012 NAS specification.
- The use of any accessories other than those provided by the manufacturer may damage panels, void all warranties and will void all engineering data.
- This material is subject to change without notice. Please contact MBCI for most current data.

The Engineering data contained herein is for the expressed use of customers and design professionals. Along with this data, it is recommended that the design professional have a copy of the most current version of the North American Specification for the Design of Cold-Formed Steel Structural Members published by the American Iron and Steel Institute to facilitate design. This Specification contains the design criteria for cold-formed steel components. Along with the Specification, the designer should reference the most current building code applicable to the project jobsite in order to determine environmental loads. If further information or guidance regarding cold-formed design practices is desired, please contact the manufacturer.



Metal Roof and Wall Systems

Houston, TX 877/713-6224
Adel, GA 888/446-6224
Atlanta, GA 877/512-6224
Atwater, CA 800/829-9324
Dallas, TX 800/653-6224
Indianapolis, IN 800/735-6224
Jackson, MS 800/622-4136

Las Vegas, NV 877/713-6224
Lewisville, TX 877/713-6224
Lubbock, TX 800/758-6224
Mattoon, IL 888/885-0468
Memphis, TN 800/206-6224
Oklahoma City, OK 800/597-6224
Omaha, NE 800/458-6224

Phoenix, AZ 888/533-6224
Richmond, VA 800/729-6224
Rome, NY 800/559-6224
Salt Lake City, UT 800/874-2404
San Antonio, TX 800/598-6224

SPECIFICATIONS

ShadowRib™

SECTION 07421313 Formed Metal Wall Panels

PART 1 - GENERAL

1.1 SECTION INCLUDES

- A. Fluted-profile, concealed fastener, lap-seam metal wall panels, with related metal trim and accessories.

1.2 RELATED REQUIREMENTS

Specifier: If retaining this optional article, edit list below to correspond to Project.

- A. Division 01 Section "Sustainable Design Requirements" for related LEED general requirements.
- B. Division 05 Section "Structural Steel Framing" for steel framing supporting metal panels.
- C. Division 05 Section "Cold-Formed Metal Framing" for cold-formed metal framing supporting metal panels.
- D. Division 07 Section "Thermal Insulation" for thermal insulation installed under metal panels.
- E. Division 07 Section "Air Barriers" for air barriers within wall assembly and adjacent to wall assembly.
- F. Division 07 Section "Metal Soffit and Wall Liner Panels" for soffit and wall liner panels installed with metal wall panels.
- G. Division 07 Section "Sheet Metal Flashing and Trim" for sheet metal flashing items in addition to items specified in this Section.
- H. Division 13 Section "Metal Building Systems" for steel framing supporting metal panels.

1.3 REFERENCES

Specifier: If retaining this optional article, edit list below to correspond to Project.

- A. **American Architectural Manufacturer's Association (AAMA):** www.aamanet.org:
- AAMA 621 - Voluntary Specifications for High Performance Organic Coatings on Coil Coated Architectural Hot Dipped Galvanized (HDG) & Zinc-Aluminum Coated Steel Substrates.
 - AAMA 809.2 Voluntary Specification Non-Drying Sealants.
- B. **American Society of Civil Engineers (ASCE):** www.asce.org/codes-standards:
- ASCE 7 - Minimum Design Loads for Buildings and Other Structures.
- C. **ASTM International (ASTM):** www.astm.org:
- ASTM A653 - Specification for Steel Sheet, Zinc-Coated (Galvanized) or Zinc-Iron Alloy-Coated (Galvannealed) by the Hot-Dip Process.
 - ASTM A755 - Specification for Steel Sheet, Metallic Coated by the Hot-Dip Process and Prepainted by the Coil-Coating Process for Exterior Exposed Building Products.

- ASTM A792/A792M - Standard Specification for Steel Sheet, 55% Aluminum-Zinc Alloy-Coated by the Hot-Dip Process.
- ASTM C920 - Specification for Elastomeric Joint Sealants.
- ASTM D2244 - Test Method for Calculation of Color Differences from Instrumentally Measured Color Coordinates.
- ASTM D4214 - Test Methods for Evaluating Degree of Chalking of Exterior Paint Films.
- ASTM E1592 - Standard Test Method for Structural Performance of Sheet Metal Roof and Siding Systems by Uniform Static Air Pressure Difference.

D. International Accreditation Service (IAS):

- IAS AC472 Accreditation Criteria for Inspection Programs for Manufacturers of Metal Building Systems, Part B.

E. US Green Building Council (USGBC): www.usgbc.org:

- Leadership in Energy and Environmental Design (LEED) Green Building Rating System.

1.4 QUALITY ASSURANCE

A. **Manufacturer/Source:** Provide metal panel assemblies and accessories from a single manufacturer accredited under IAS AC472, Part B.

B. **Manufacturer Qualifications:** Approved manufacturer listed in this Section with minimum five years experience in manufacture of similar products in successful use in similar applications.

Specifier: Retain paragraph below if Owner allows substitutions but requires strict control over qualifying of substituted manufacturers.

- Approval of Comparable Products: Submit the following in accordance with project substitution requirements, within time allowed for substitution review:
 - Product data, including certified independent test data indicating compliance with requirements.
 - Samples of each component.
 - Sample submittal from similar project.
 - Project references: Minimum of five installations not less than five years old, with Owner and Architect contact information.
 - Sample warranty.
 - Certificate of accreditation under IAS AC472 Part B.
- Substitutions following award of contract are not allowed except as stipulated in Division 01 General Requirements.
- Approved manufacturers must meet separate requirements of Submittals Article.

Specifier: Review of manufacturers' qualifying of installers is recommended. MBCI requires Installer and supervisor certification when project requirements include extended warranty.

ShadowRib™

SPECIFICATIONS

C. Installer Qualifications: Experienced Installer [certified by metal panel manufacturer] with minimum of five years experience with successfully completed projects of a similar nature and scope.

1. Installer's Field Supervisor: Experienced mechanic [certified by metal panel manufacturer] supervising work on site whenever work is underway.

Specifier: Retain paragraph below and edit as appropriate for Federal projects and for public works projects utilizing Federal funds; consult with project Contracting Officer. Coordinate with Submittals Article.

D. Buy American Compliance: Materials provided under work of this Section shall comply with the following requirements:

1. Buy American Act of 1933 BAA-41 U.S.C §§ 10a – 10d.
2. Buy American provisions of Section 1605 of the American Recovery and Reinvestment Act of 2009 (ARRA).

E. Steel Construction Publications: Comply with published recommendations in the following, unless more stringent requirements are indicated.

1. American Institute of Steel Construction (AISC): "Steel Construction Manual."
2. American Iron and Steel Institute (AISI): "Cold Formed Steel Design Manual."

1.5 ADMINISTRATIVE REQUIREMENTS

A. Preinstallation Meeting: Prior to erection of framing, conduct preinstallation meeting at site attended by Owner, Architect, metal panel installer, metal panel manufacturer's technical representative, inspection agency and related trade contractors.

1. Coordinate building framing in relation to metal panel system.
2. Coordinate openings and penetrations of metal panel system.
3. Coordinate work of Division 07 Sections "Roof Specialties" and "Roof Accessories" and openings and penetrations and manufacturer's accessories with installation of metal panels.

1.6 ACTION SUBMITTALS

A. Product Data: Manufacturer's data sheets for specified products. Include data indicating compliance with performance requirements.

Specifier: Retain and edit below to comply with Project requirements for LEED or other sustainable design requirements.

B. LEED Submittals:

1. Credit MR 4 Recycled Content: Product data indicating the following:
 - a. Material costs for each product having recycled content.
 - b. Percentages by weight of post-consumer and pre-consumer recycled content for each item.
 - c. Total weight of products provided.
2. Credit IEQ 4.1 Low-Emitting Materials - Adhesives

and Sealants: Product data for sealants and sealant primers used inside the weatherproofing system, indicating VOC content.

C. Shop Drawings: Show layouts of metal panels. Include details of each condition of installation, panel profiles, and attachment to building. Provide details at a minimum scale 1-1/2-inch per foot of edge conditions, joints, fastener and sealant placement, flashings, openings, penetrations, and special details. Make distinctions between factory and field assembled work.

1. Indicate points of supporting structure that must coordinate with metal panel system installation.
2. Include structural data indicating compliance with performance requirements and requirements of local authorities having jurisdiction.

D. Samples for Initial Selection: For each exposed product specified including sealants. Provide representative color charts of manufacturer's full range of colors.

E. Samples for Verification: Provide 12-inch- (305 mm-) long section of each metal panel profile. Provide color chip verifying color selection.

1.7 INFORMATIONAL SUBMITTALS

- A. Product Test Reports:** Indicating compliance of products with requirements.
- B. Qualification Information:** For Installer firm and Installer's field supervisor.
- C. IAS Accreditation Certificate:** Indicating that manufacturer is accredited under provisions of IAS AC472 Part B.
- D. Buy American Certification:** Manufacturers' letters of compliance acceptable to authorities having jurisdiction, indicating that products comply with requirements.
- E. Florida State Building Code Certificate:** Indicating that products comply with requirements of Florida State Building Code. www.floridabuilding.org/pr/pr_app_srch.aspx
- F. Manufacturer's warranty:** Unexecuted sample copy of manufacturer's warranty.

1.8 CLOSEOUT SUBMITTALS

- A. Maintenance data.**
- B. Manufacturer's Warranty:** Executed copy of manufacturer's warranty.

1.9 DELIVERY, STORAGE, AND HANDLING

A. Protect products of metal panel system during shipping, handling, and storage to prevent staining, denting, deterioration of components or other damage. Protect panels and trim bundles during shipping.

1. Deliver, unload, store, and erect metal panels and accessory items without misshaping panels or expos-



Metal Roof and Wall Systems

Houston, TX 877/713-6224
 Adel, GA 888/446-6224
 Atlanta, GA 877/512-6224
 Atwater, CA 800/829-9324
 Dallas, TX 800/653-6224
 Indianapolis, IN 800/735-6224
 Jackson, MS 800/622-4136

Las Vegas, NV 877/713-6224
 Lewisville, TX 877/713-6224
 Lubbock, TX 800/758-6224
 Mattoon, IL 888/885-0468
 Memphis, TN 800/206-6224
 Oklahoma City, OK 800/597-6224
 Omaha, NE 800/458-6224

Phoenix, AZ 888/533-6224
 Richmond, VA 800/729-6224
 Rome, NY 800/559-6224
 Salt Lake City, UT 800/874-2404
 San Antonio, TX 800/598-6224

SPECIFICATIONS

ShadowRib™

ing panels to surface damage from weather or construction operations.

2. Store in accordance with Manufacturer's written instruction. Provide wood collars for stacking and handling in the field.
3. Shield foam insulated metal panels from direct sunlight until installation.

1.10 WARRANTY

Specifier: Warranty terms below are available from MBCI. Verify that other allowable manufacturers furnish warranty meeting requirements.

A. Special Manufacturer's Warranty: On manufacturer's standard form, in which manufacturer agrees to repair or replace metal panel assemblies that fail in materials and workmanship within [one] year from date of Substantial Completion.

B. Special Panel Finish Warranty: On Manufacturer's standard form, in which Manufacturer agrees to repair or replace metal panels that evidence deterioration of factory-applied finish within the warranty period, as follows:

Specifier: Retain finish warranty paragraph that corresponds to selected metal panel finish system.

Several exotic and metallic colors are available from MBCI with limited warranty periods; verify warranty period for selected colors with manufacturer.

1. Fluoropolymer Two-Coat System:
 - a. Basis of Design System: MBCI, Signature 300.
 - b. Color fading in excess of 5 Hunter units per ASTM D2244.
 - c. Chalking in excess of No. 8 rating per ASTM D4214.
 - d. Failure of adhesion, peeling, checking, or cracking.
 - e. Warranty Period: [40] years from date of Substantial Completion.
2. Modified Silicone-Polyester Two-Coat System:
 - a. Basis of Design System: MBCI, Signature 200.
 - b. Color fading in excess of 7 Hunter units per ASTM D2244.
 - c. Chalking in excess of No. 6 rating per ASTM D4214.
 - d. Failure of adhesion, peeling, checking, or cracking.
 - e. Warranty Period: [30] years from date of Substantial Completion.

PART 2 - PRODUCTS

2.1 MANUFACTURER

Specifier: Retain basis of design manufacturer and products listed in this Article where allowed. If inserting comparable manufacturers, carefully review products and engineering capabilities in relation to requirements of this Section, to ensure that other approved manufacturers offer products meeting MBCI's standards.

A. Basis of Design Manufacturer: MBCI Metal Roof and Wall Systems, Division of NCI Group, Inc.; Houston TX. Tel: (877)713-6224; Email: info@ecoficientseries.com; Web: www.mbc.com.

1. Provide basis of design product[, or comparable product approved by Architect prior to bid].

2.2 PERFORMANCE REQUIREMENTS

A. General: Provide metal panel system meeting performance requirements as determined by application of specified tests by a qualified testing facility on manufacturer's standard assemblies.

Specifier: Recycled Content paragraph below describes calculation utilized for LEED-NC Credit MR 4. Modify as required to meet project recycled content requirements, or delete if recycled content requirements are stipulated solely in Division 01 Section "Sustainable Design Requirements."

B. Recycled Content: For Steel Products: Postconsumer recycled content plus one-half of preconsumer recycled content not less than [25] percent.

C. Structural Performance: Provide metal panel assemblies capable of withstanding the effects of indicated loads and stresses within limits and under conditions indicated, as determined by ASTM E1592:

Specifier: Consult structural engineer and edit below as required by local codes. Insert structural data below if not indicated on drawings. Select applicable deflection limit.

1. Wind Loads: Determine loads based on uniform pressure, importance factor, exposure category, and basic wind speed indicated on drawings.
 - a. Wind Negative Pressure: Certify capacity of metal panels by actual testing of proposed assembly.
2. Deflection Limits: Withstand inward and outward wind-load design pressures in accordance with applicable building code with maximum deflection of 1/120 of the span with no evidence of failure.
3. Seismic Performance: Comply with ASCE 7 Sections 9, "Earthquake Loads."

D. Florida State Building Code Compliance: Provide metal roof and wall panels complying with requirements for installation under Florida State Building Code outside of high velocity wind zone.

E. Thermal Movements: Allow for thermal movements from variations in both ambient and internal temperatures. Accommodate movement of support structure caused by thermal expansion and contraction. Allow for deflection and design for thermal stresses caused by temperature differences from one side of the panel to the other.

2.3 FORMED METAL WALL PANELS

A. Fluted-Profile, Concealed Fastener Metal Wall Panels: Structural metal panels consisting of formed metal sheet with vertical panel edges and tapered inverted intermediate rib 5-1/2 by 1-1/2 inches (140 by 38 mm), with flush joints between panels, field

ShadowRib™

GENERAL INFORMATION

assembled with nested lapped edges, and attached to supports using concealed fasteners.

1. Basis of Design: MBCI, ShadowRib.

Specifier: Material description below corresponds to BIEC International, Inc. <http://galvalume.com/> Galvalume substrate, available Prepainted from MBCI.

Second paragraph below describes Galvalume Plus with clear acrylic coating for use as exposed metallic finish.

2. Aluminum-Zinc Alloy-Coated Steel Sheet: ASTM A792/A792M, structural quality, Grade 50, Coating Class AZ50 (Grade 340, Coating Class AZM150), prepainted by the coil-coating process per ASTM A755/A755M.

Specifier: Prior to selecting metal thickness and panel thickness below, consult manufacturer's span tables and review selection against panel thickness requirements and span condition. Select appropriate panel configuration to meet requirements of design wind pressure. Important: Consult this document when specifying gauge with the intent that it meet a prescriptive decimal thickness requirement in addition to strength performance requirements. (Click Here to View)

a. Nominal Thickness: [24 gage] [22 gage] coated thickness, with [smooth] [stucco embossed] surface.

1) Exterior Finish: [Modified silicone-polyester two-coat system] [Fluoropolymer two-coat system] [Fluoropolymer two-coat metallic color system] [Exposed Galvalume Plus coating].

2) Color: [As indicated] [As selected by Architect from manufacturer's standard colors] [Match Architect's custom color].

3. Panel Width: 16 inches (406 mm).

4. Panel Thickness: 3 inch (76 mm).

2.4 MISCELLANEOUS MATERIALS

A. General: Provide complete metal panel assemblies incorporating trim, copings, fasciae, gutters and downspouts, and miscellaneous flashings. Provide required fasteners, closure strips, and sealants as indicated in manufacturer's written instructions.

B. Flashing and Trim: Match material, thickness, and finish of metal panels.

C. Panel Clips: ASTM A653/A653M, G90 (Z180) hot-dip galvanized, one-piece clips, configured for concealment in panel joints, enabling installation of fasteners from exterior, and identical to clips utilized in tests demonstrating compliance with performance requirements.

D. Panel Fasteners: Self-tapping screws and other acceptable fasteners recommended by metal panel manufacturer. Where exposed fasteners cannot be avoided, supply corrosion-resistant fasteners with heads matching color of metal panels by means of factory-applied coating, with weathertight resilient washers.

E. Panel Sealants:

1. VOC Content of Interior Sealants: Sealants used

inside the weatherproofing system shall comply with the following limits for VOC content when calculated according to 40 CFR 59, Subpart D (EPA Method 24):

a. Architectural Sealants: 250 g/L.

2.5 FABRICATION

A. General: Provide factory fabricated and finished metal panels, trim, and accessories meeting performance requirements, indicated profiles, and structural requirements.

B. Sheet Metal Flashing and Trim: Fabricate flashing and trim to comply with manufacturer's written instructions, approved shop drawings, and project drawings.

2.6 FINISHES

A. Finishes, General: Prepare, pretreat, and apply coating to exposed metal surfaces to comply with coating and resin manufacturers' written instructions.

B. Modified Silicone-Polyester Two-Coat System: 0.20 – 0.25 mil primer with 0.7 – 0.8 mil color coat[, meeting solar reflectance index requirements].

1. Basis of Design: MBCI, Signature 200.

Specifier: MBCI's fluoropolymer coatings are based on Arkema, Inc. Kynar 500 and Solvay Solexis Hylar 500 PVF2 resins.

C. Fluoropolymer Two-Coat System: 0.2 – 0.3 mil primer with 0.7 - 0.8 mil 70 percent PVDF fluoropolymer color coat, AAMA 621[, meeting solar reflectance index requirements].

1. Basis of Design: MBCI, Signature 300.

PART 3 - EXECUTION

3.1 EXAMINATION

A. Examine metal panel system substrate with Installer present. Inspect for erection tolerances and other conditions that would adversely affect installation of metal panels.

1. Inspect framing that will support insulated metal panels to determine if support components are installed as indicated on approved shop drawings and are within tolerances acceptable to metal panel manufacturer and installer. Confirm presence of acceptable framing members at recommended spacing to match installation requirements of metal panels.

B. Correct out-of-tolerance work and other deficient conditions prior to proceeding with insulated metal panel installation.

3.2 METAL PANEL INSTALLATION

A. Concealed-Fastener Formed Metal Panels: Install metal panel system in accordance with manufacturer's written instructions, approved shop drawings, and project drawings. Install metal panels in orienta-



Metal Roof and Wall Systems

Houston, TX 877/713-6224
Adel, GA 888/446-6224
Atlanta, GA 877/512-6224
Atwater, CA 800/829-9324
Dallas, TX 800/653-6224
Indianapolis, IN 800/735-6224
Jackson, MS 800/622-4136

Las Vegas, NV 877/713-6224
Lewisville, TX 877/713-6224
Lubbock, TX 800/758-6224
Mattoon, IL 888/885-0468
Memphis, TN 800/206-6224
Oklahoma City, OK 800/597-6224
Omaha, NE 800/458-6224

Phoenix, AZ 888/533-6224
Richmond, VA 800/729-6224
Rome, NY 800/559-6224
Salt Lake City, UT 800/874-2404
San Antonio, TX 800/598-6224

GENERAL INFORMATION

ShadowRib™

tion, sizes, and locations indicated. Anchor panels and other components securely in place. Provide for thermal and structural movement.

B. Attach panels to metal framing using clips, screws, and sealants recommended for application by metal panel manufacturer.

1. Fasten metal panels to supports with fasteners at each location indicated on approved shop drawings, at spacing and with fasteners recommended by manufacturer.
2. Cut panels in field where required using manufacturer's recommended methods.
3. Provide weatherproof jacks for pipe and conduit penetrating metal panels.
4. Dissimilar Materials: Where elements of metal panel system will come into contact with dissimilar materials, treat faces and edges in contact with dissimilar materials as recommended by metal panel manufacturer.
5. Interior Fastener Attachment: Nest panel flanges and drill through support framing and overlapped panel flanges, and secure to structure using manufacturer's expansion fastener.
6. Exterior Clip Attachment: Attach leading panel flange to structural support using manufacturer's standard clip secured with self-tapping screw faster. Nest panel flange of subsequent panel fully in secured panel flange, ensuring panel faces are flush, and secure subsequent panel to previous panel using manufacturer's recommended fastener.
7. Vertical Panel Joint Sealant: Apply continuous bead of manufacturer's recommended elastomeric joint sealant in concealed joint between panels.

C. Attach panel flashing trim pieces to supports using recommended fasteners.

3.3 ACCESSORY INSTALLATION

A. General: Install metal panel accessories with positive anchorage to building and weather tight mounting; provide for thermal expansion. Coordinate installation with flashings and other components.

1. Install components required for a complete metal panel assembly, including trim, copings, flashings, sealants, closure strips, and similar items.
2. Comply with details of assemblies utilized to establish compliance with performance requirements and manufacturer's written installation instructions.
3. Set units true to line and level as indicated. Install work with laps, joints, and seams that will be permanently weather resistant.

3.4 CLEANING AND PROTECTION

A. Clean finished surfaces as recommended by metal panel manufacturer.

B. Replace damaged panels and accessories that cannot be repaired to the satisfaction of the Architect.

END OF SECTION

ShadowRib™

GENERAL INFORMATION

PRODUCT CHECKLIST

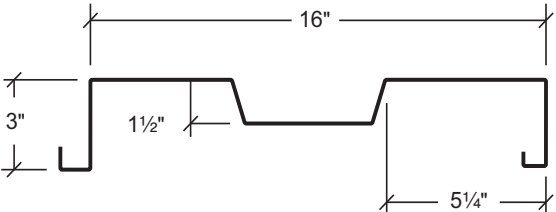
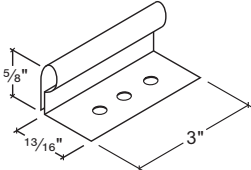
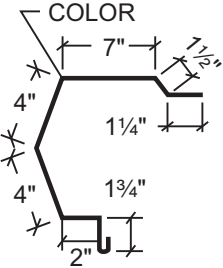
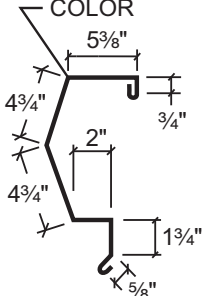
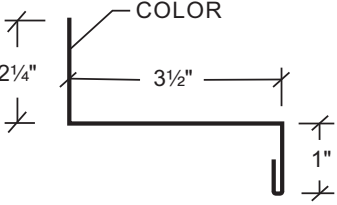
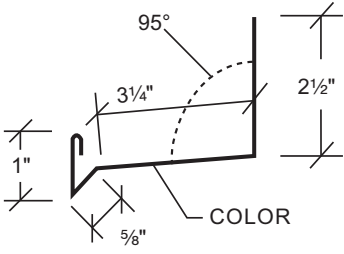
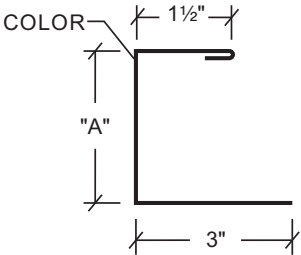
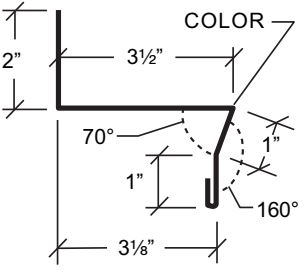
<p>ShadowRib™ Panel</p>  <p><input type="checkbox"/> • 16 Gauge Painted <input type="checkbox"/> HW-6602</p>	<p>ShadowRib™ Clip</p>  <p><input type="checkbox"/> • 16 Gauge Painted <input type="checkbox"/> HW-6602</p>
<p>ShadowRib™ Rake Trim</p>  <p>• For use with "R" Panel Roofs T-6111 <input type="checkbox"/></p>	<p>ShadowRib™ Rake Trim</p>  <p>• For use with Ultra-Dek® & Double-Lok® Roofs T-6101 <input type="checkbox"/></p>
<p>ShadowRib™ Base Trim</p>  <p><input type="checkbox"/> T-6011</p>	<p>ShadowRib™ Head Trim</p>  <p><input type="checkbox"/> T-6083</p>
<p>ShadowRib™ Cap/Jamb Trim</p>  <p>DIM "A" 3 3/8" T-6071 <input type="checkbox"/> 1 1/2" T-6073 <input type="checkbox"/></p>	<p>ShadowRib™ Splice Trim</p>  <p><input type="checkbox"/> T-6121</p>

NOTE: All trim to be 26 gauge material unless noted



Metal Roof and Wall Systems

Houston, TX 877/713-6224
 Adel, GA 888/446-6224
 Atlanta, GA 877/512-6224
 Atwater, CA 800/829-9324
 Dallas, TX 800/653-6224
 Indianapolis, IN 800/735-6224
 Jackson, MS 800/622-4136



Las Vegas, NV 877/713-6224
 Lewisville, TX 877/713-6224
 Lubbock, TX 800/758-6224
 Mattoon, IL 888/885-0468
 Memphis, TN 800/206-6224
 Oklahoma City, OK 800/597-6224
 Omaha, NE 800/458-6224

Phoenix, AZ 888/533-6224
 Richmond, VA 800/729-6224
 Rome, NY 800/559-6224
 Salt Lake City, UT 800/874-2404
 San Antonio, TX 800/598-6224

GENERAL INFORMATION

ShadowRib™

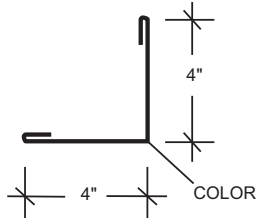
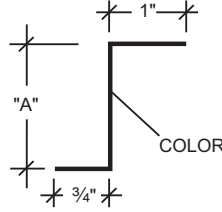
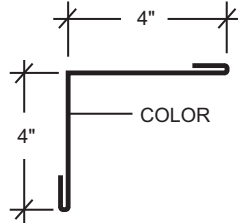
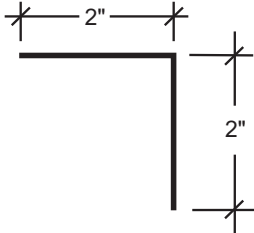
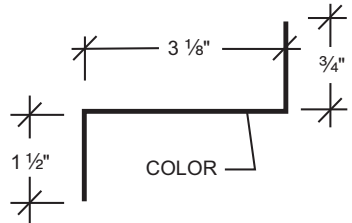
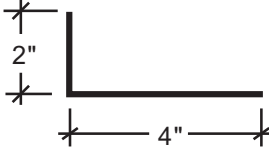
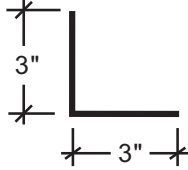
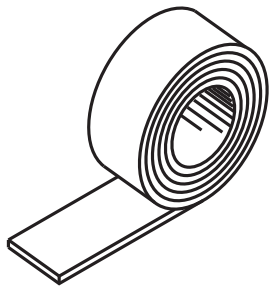



PRODUCT CHECKLIST

<p>ShadowRib™ Outside Corner</p>  <p>T-6023 <input type="checkbox"/></p>	<p>ShadowRib™ Furring Zee</p>  <p>DIM "A" 3 1/8" T-6132 <input type="checkbox"/> 1 1/2" T-6131 <input type="checkbox"/></p>
<p>ShadowRib™ Inside Corner</p>  <p>T-6053 <input type="checkbox"/></p>	<p>ShadowRib™ Starter Angle</p>  <p>HW-4650 <input type="checkbox"/></p>
<p>Zee Cap</p>  <p>T-6133 <input type="checkbox"/></p>	<p>4" x 2" Angle</p>  <p>3" x 3" Angle</p>  <p><input type="checkbox"/></p> <p><input type="checkbox"/></p>
<p>Foam Tape</p>  <p>HW-516 <input type="checkbox"/></p>	<p>ShadowRib™ Closures</p> <p>Outside</p>  <p>HW-412 <input type="checkbox"/></p> <p>Inside</p>  <p>HW-410 <input type="checkbox"/></p>

NOTE: All trim to be 26 gauge material unless noted

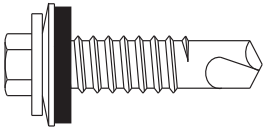
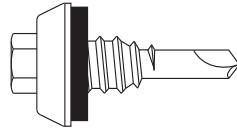
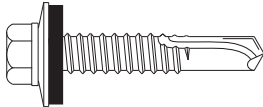
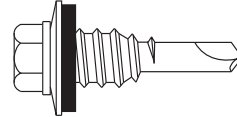
ShadowRib™ GENERAL INFORMATION

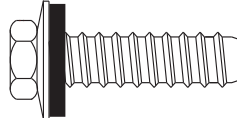
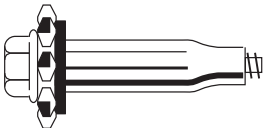
PRODUCT CHECKLIST

<p>Fastener #1</p> <ul style="list-style-type: none"> • Clip to 16-12 gauge girt • Panel to clip • Panel to starter angle  <p>1/4"-14 x 1" Driller 3/8" Hex Washer Head with 5/8" O.D. washer <input type="checkbox"/></p>	<p>Fastener #4</p> <ul style="list-style-type: none"> • Trim to panel  <p>1/4"-14 x 7/8" Long Life Lap TEK 5/16" Hex Washer Head, with sealing washer <input type="checkbox"/></p>
<p>Fastener #6</p> <ul style="list-style-type: none"> • Clip to Structural 3/8" max. tickness  <p>12-24 x 1 1/4" TEK 4.5 5/16" Hex Washer Head with 5/8" O.D. washer <input type="checkbox"/></p>	<p>Fastener #4A</p> <ul style="list-style-type: none"> • Use to fasten panels together at clip locations  <p>1/4"-14 x 7/8" Lap TEK 5/16" Hex Washer Head, with 5/8" O.D. washer <input type="checkbox"/></p>
<p>Fastener #14</p> <ul style="list-style-type: none"> • Trim to trim • Trim to panel  <p>1/8" x 3/16" Pop Rivet 1/8" Diameter x 3/16" Grip Range <input type="checkbox"/></p>	<p>Fastener #10</p>  <p>1/4"-14 x 1" Type B 3/8" Hex Washer Head with 5/8" O.D. washer <input type="checkbox"/></p>
<p>Fastener #23</p> <ul style="list-style-type: none"> • For use with inside attachment method  <p>Fas.10-4 5/16" Hex Washer Head, with 5/8" O.D. washer <input type="checkbox"/></p>	<p>Fastener #14A</p> <ul style="list-style-type: none"> • Window frame to structural • Trim to structural • Starter angle to structural  <p>1/8" x 3/8" Pop Rivet 1/8" Diameter x 3/8" Grip Range <input type="checkbox"/></p>



Metal Roof and Wall Systems

Houston, TX 877/713-6224
Adel, GA 888/446-6224
Atlanta, GA 877/512-6224
Atwater, CA 800/829-9324
Dallas, TX 800/653-6224
Indianapolis, IN 800/735-6224
Jackson, MS 800/622-4136

Las Vegas, NV 877/713-6224
Lewisville, TX 877/713-6224
Lubbock, TX 800/758-6224
Mattoon, IL 888/885-0468
Memphis, TN 800/206-6224
Oklahoma City, OK 800/597-6224
Omaha, NE 800/458-6224

Phoenix, AZ 888/533-6224
Richmond, VA 800/729-6224
Rome, NY 800/559-6224
Salt Lake City, UT 800/874-2404
San Antonio, TX 800/598-6224

GENERAL INFORMATION

ShadowRib™

ShadowRib™ INSTALLATION GUIDELINES

I. Pre-Order

- A. Prior To Ordering Panels, All Dimensions Should Be Confirmed By Field Measurement.

II. Jobsite Storage And Handling

- A. Check the shipment against the shipping list.
- B. Damaged material must be noted on bill of lading.
- C. Panel crates should be handled carefully. A spreader bar of appropriate length is recommended for hoisting.
- D. Check to see that moisture has not formed inside the bundles during shipment. If moisture is present, panels should be uncrated and wiped dry, then restacked and loosely covered so that air can circulate between the panels.

III. Application checklist

- A. Check substructure for proper alignment and uniformity to avoid panel distortion.
- B. All primary and secondary framing must be erected, plumbed and squared with bolts tightened according to accepted building practices prior to beginning the installation of the Shadowrib™ panel.
- C. MBCI recommends that all framed openings begin and end in the "high".
- D. For installation of long panel runs, mbcI recommends the clip method.
- E. Periodic check of panel alignment is crucial to proper panel alignment.
- F. If there is a conflict between this manual and the project erection drawings, the erection drawings will take precedence.
- G. MBCI recommends the use of a screw gun with a speed range of 0 - 2000 rpm to properly install all fasteners referenced in this manual. Tools rated to 4000 rpm should never be used for self drilling fasteners typically applied with metal building components.

ShadowRib™

GENERAL INFORMATION

RIGHT WAY

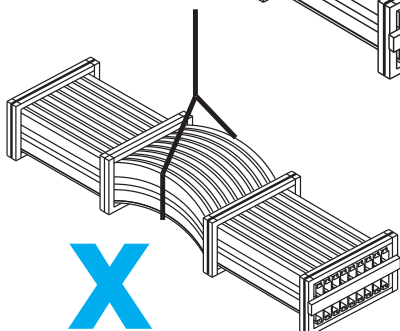
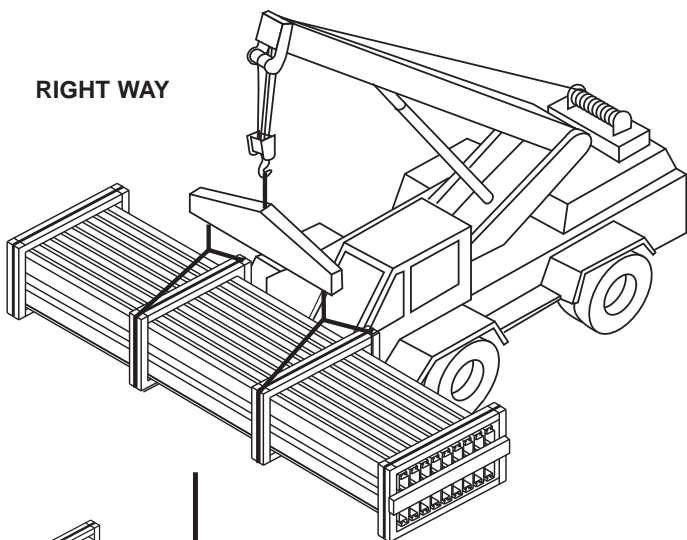

WRONG WAY

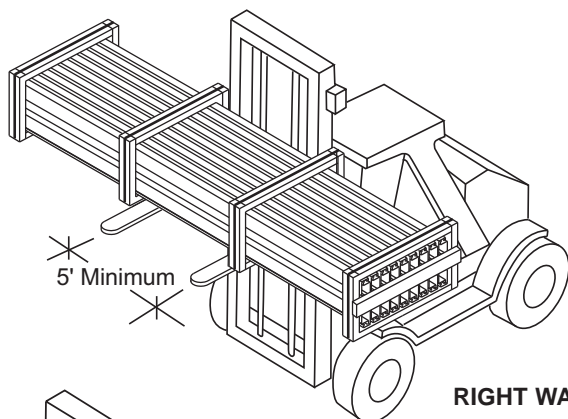

RIGHT WAY

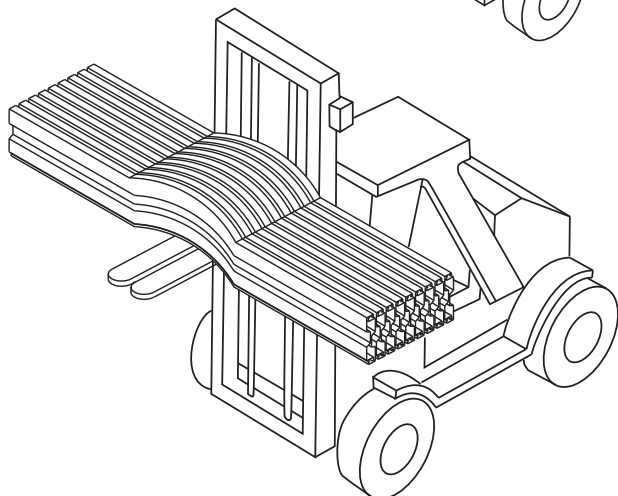

WRONG WAY

UNLOADING

Upon receiving material, check shipment against shipping list for shortages and damages. MBCI will not be responsible for shortages or damages unless they are noted on the shipping list.

Each bundle should be lifted at its center of gravity. Where possible, bundles should remain banded until final placement on roof. If bundles must be opened, they should be retied before lifting.

When lifting bundles with a crane, a spreader bar and nylon straps should be used. NEVER USE WIRE ROPE SLINGS, THEY WILL DAMAGE THE PANELS.

When lifting bundles with a forklift, forks must be a minimum of five feet apart. Do not transport open bundles. Drive slowly when crossing rough terrain to prevent panel buckling.

CAUTION

Improper unloading and handling of bundles and crates may cause bodily injury or material damage. The manufacturer is not responsible for bodily injuries or material damages during unloading and storage.



Metal Roof and Wall Systems

Houston, TX 877/713-6224
Adel, GA 888/446-6224
Atlanta, GA 877/512-6224
Atwater, CA 800/829-9324
Dallas, TX 800/653-6224
Indianapolis, IN 800/735-6224
Jackson, MS 800/622-4136

Las Vegas, NV 877/713-6224
Lewisville, TX 877/713-6224
Lubbock, TX 800/758-6224
Mattoon, IL 888/885-0468
Memphis, TN 800/206-6224
Oklahoma City, OK 800/597-6224
Omaha, NE 800/458-6224

Phoenix, AZ 888/533-6224
Richmond, VA 800/729-6224
Rome, NY 800/559-6224
Salt Lake City, UT 800/874-2404
San Antonio, TX 800/598-6224

GENERAL INFORMATION

ShadowRib™

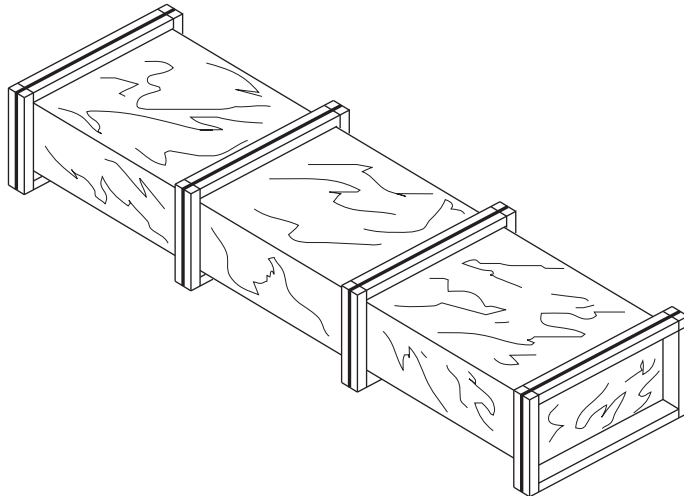
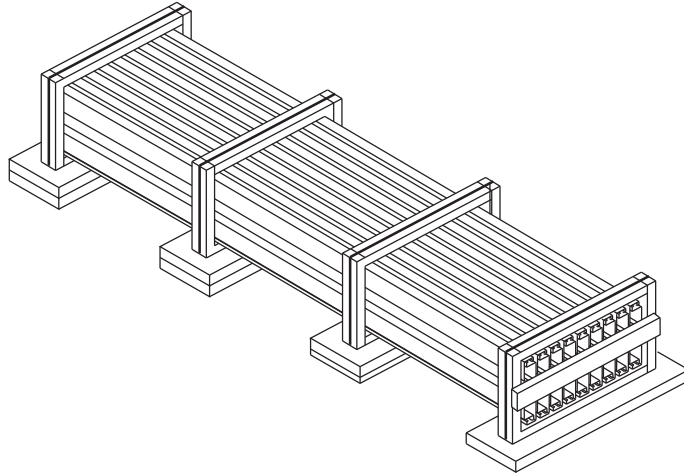

UNLOADING (continued)

BLOCK AND BAND

This method of bundling is used for orders that are to be picked up by the customer or shipped by common carrier. 2 x 4's are strapped under the bundles to allow access for straps or a forklift. Bundles less than 25' long may be handled by a forklift. The forklift should have at least 5' between forks. Bundles longer than 25' should be lifted utilizing a spreader bar with nylon straps.

FULL CRATE

This method is used on all overseas shipments or by customer's order. Handling requirements are the same as block and band.

ShadowRib™

INSTALLATION

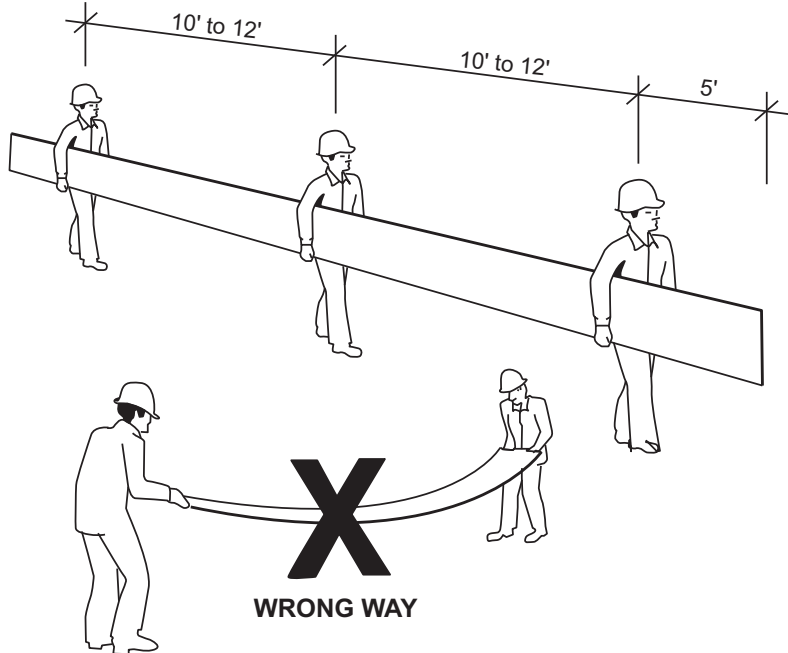

HANDLING/ PANEL STORAGE

Standing on one side of the panel, lift it by the seam. If the panel is over 10' long, lift it with two or more people on one side of the panel to prevent buckling.

Do not pick panels up by the ends.

NOTE

Protective gloves should always be used while handling panels. OSHA safety regulations must be followed at all times.

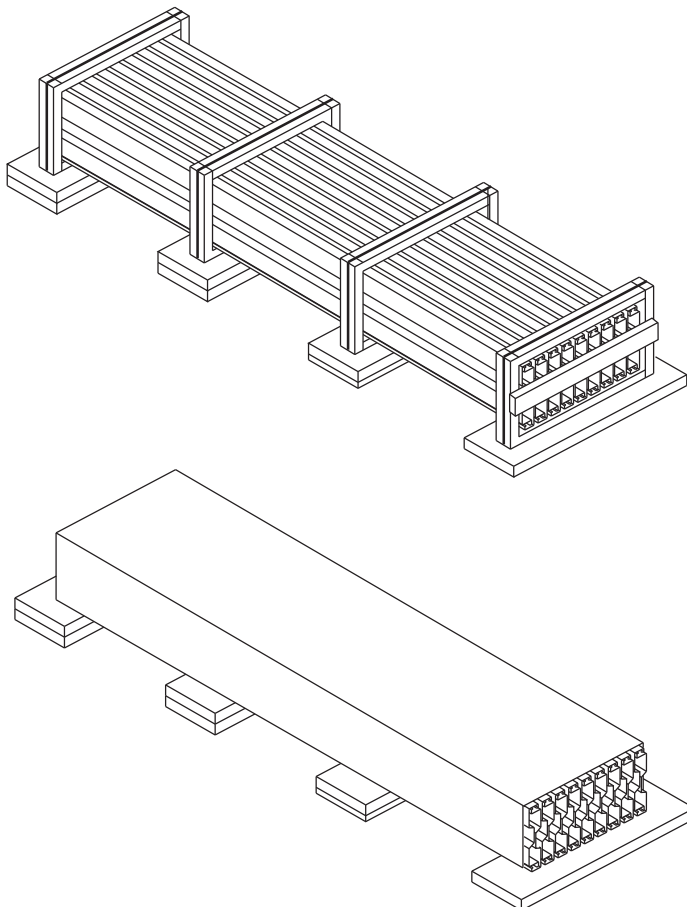

Store bundled sheets off the ground sufficiently high to allow air circulation beneath bundle and to prevent rising water from entering bundle. Slightly elevate one end of bundle. Prevent rain from entering bundle by covering with tarpaulin, making provision for air circulation between draped edges of tarpaulin and the ground. **PROLONGED STORAGE OF SHEETS IN A BUNDLE IS NOT RECOMMENDED.** If conditions do not permit immediate erection, extra care should be taken to protect sheets from white rust or water marks.

Check to see that moisture has not formed inside the bundles during shipment. If moisture is present, panels should be uncrated and wiped dry, then restacked and loosely covered so that air can circulate between the panels.



Metal Roof and Wall Systems

Houston, TX 877/713-6224
Adel, GA 888/446-6224
Atlanta, GA 877/512-6224
Atwater, CA 800/829-9324
Dallas, TX 800/653-6224
Indianapolis, IN 800/735-6224
Jackson, MS 800/622-4136

Las Vegas, NV 877/713-6224
Lewisville, TX 877/713-6224
Lubbock, TX 800/758-6224
Mattoon, IL 888/885-0468
Memphis, TN 800/206-6224
Oklahoma City, OK 800/597-6224
Omaha, NE 800/458-6224

Phoenix, AZ 888/533-6224
Richmond, VA 800/729-6224
Rome, NY 800/559-6224
Salt Lake City, UT 800/874-2404
San Antonio, TX 800/598-6224

INSTALLATION

ShadowRib™

PANEL ATTACHMENT METHODS

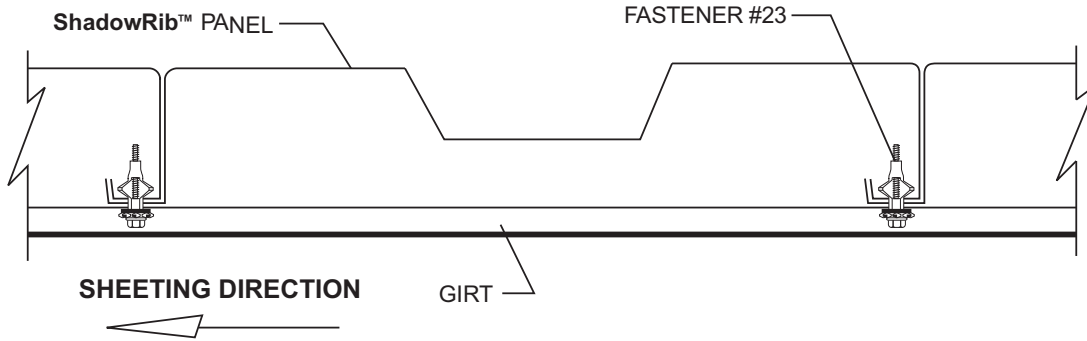

INTERIOR FASTENER ATTACHMENT

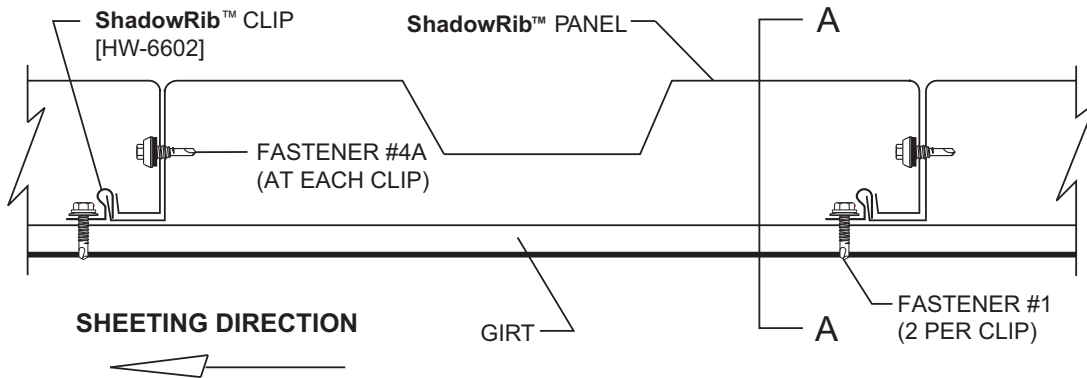

EXTERIOR CLIP ATTACHMENT

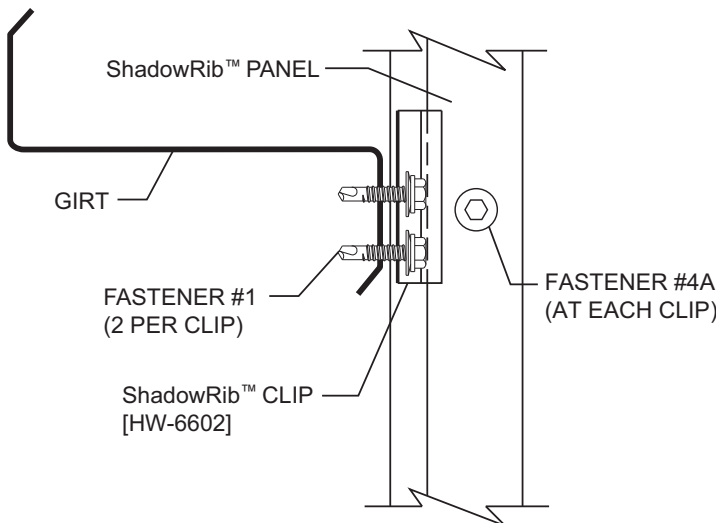

SECTION A-A

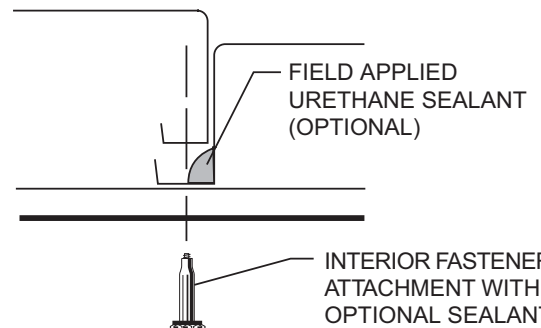
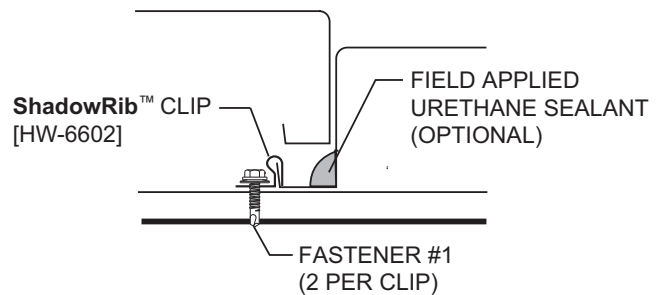

Houston, TX 877/713-6224
 Adel, GA 888/446-6224
 Atlanta, GA 877/512-6224
 Atwater, CA 800/829-9324
 Dallas, TX 800/653-6224
 Indianapolis, IN 800/735-6224
 Jackson, MS 800/622-4136

Las Vegas, NV 877/713-6224
 Lewisville, TX 877/713-6224
 Lubbock, TX 800/758-6224
 Mattoon, IL 888/885-0468
 Memphis, TN 800/206-6224
 Oklahoma City, OK 800/597-6224
 Omaha, NE 800/458-6224

Phoenix, AZ 888/533-6224
 Richmond, VA 800/729-6224
 Rome, NY 800/559-6224
 Salt Lake City, UT 800/874-2404
 San Antonio, TX 800/598-6224

ShadowRib™

INSTALLATION

PANEL ATTACHMENT METHODS

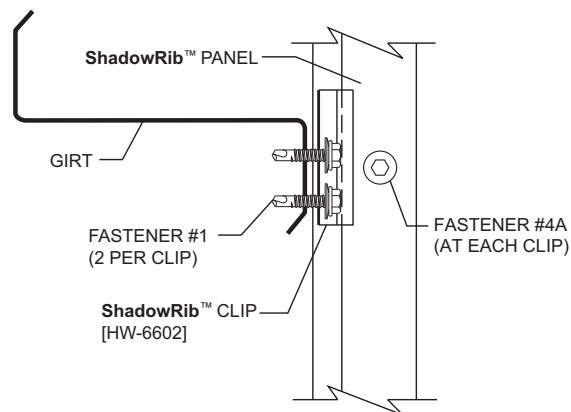
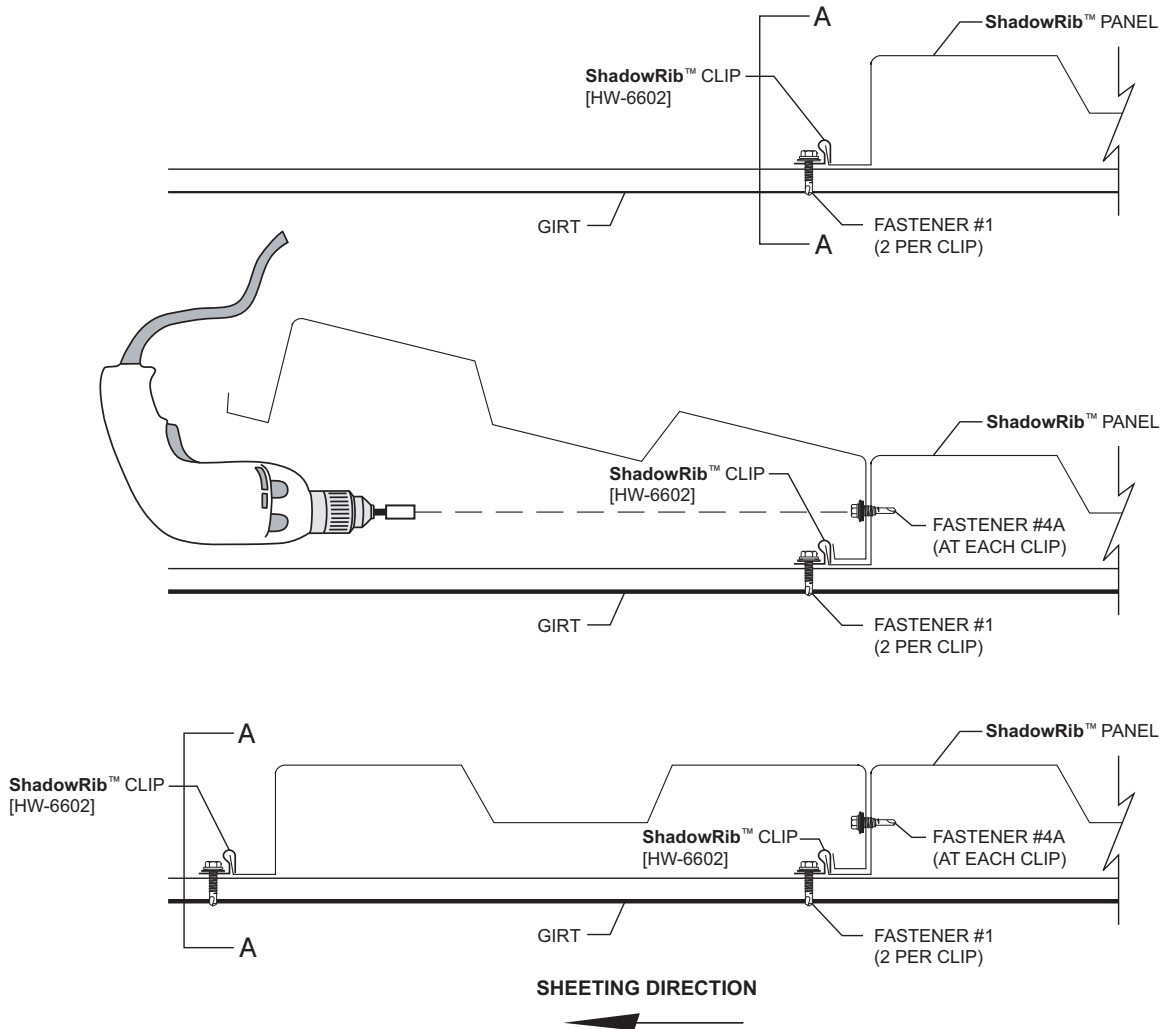

SECTION A-A



Metal Roof and Wall Systems

Houston, TX 877/713-6224
 Adel, GA 888/446-6224
 Atlanta, GA 877/512-6224
 Atwater, CA 800/829-9324
 Dallas, TX 800/653-6224
 Indianapolis, IN 800/735-6224
 Jackson, MS 800/622-4136

Las Vegas, NV 877/713-6224
 Lewisville, TX 877/713-6224
 Lubbock, TX 800/758-6224
 Mattoon, IL 888/885-0468
 Memphis, TN 800/206-6224
 Oklahoma City, OK 800/597-6224
 Omaha, NE 800/458-6224

Phoenix, AZ 888/533-6224
 Richmond, VA 800/729-6224
 Rome, NY 800/559-6224
 Salt Lake City, UT 800/874-2404
 San Antonio, TX 800/598-6224

INSTALLATION

ShadowRib™

PANEL CLIP ATTACHMENT

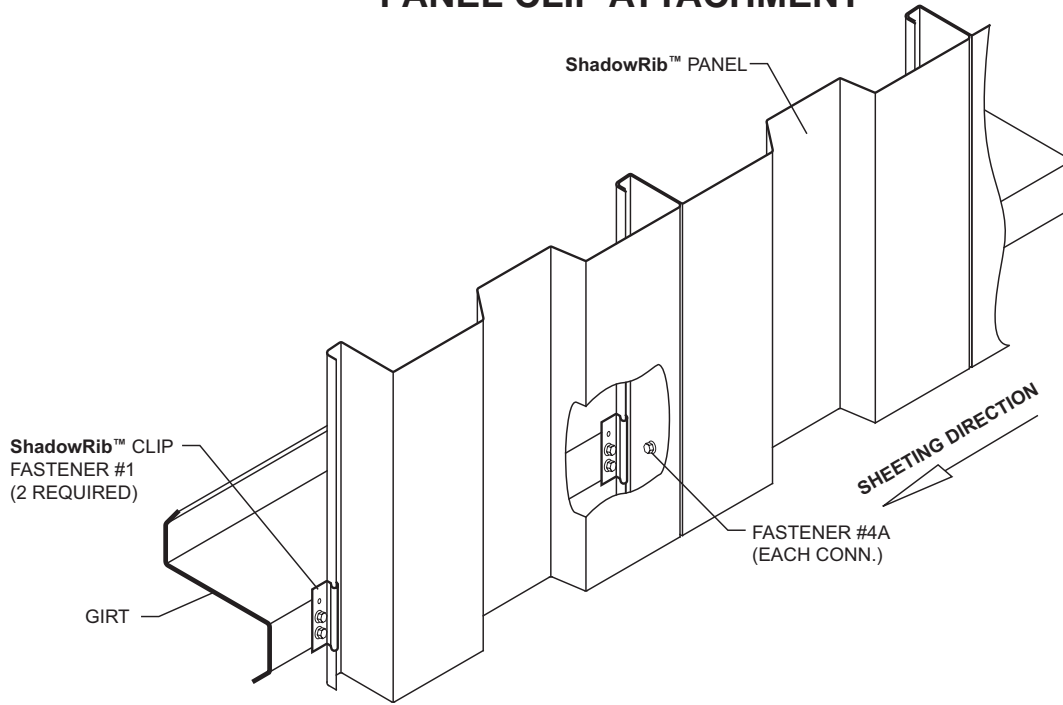

GIRT DETAIL

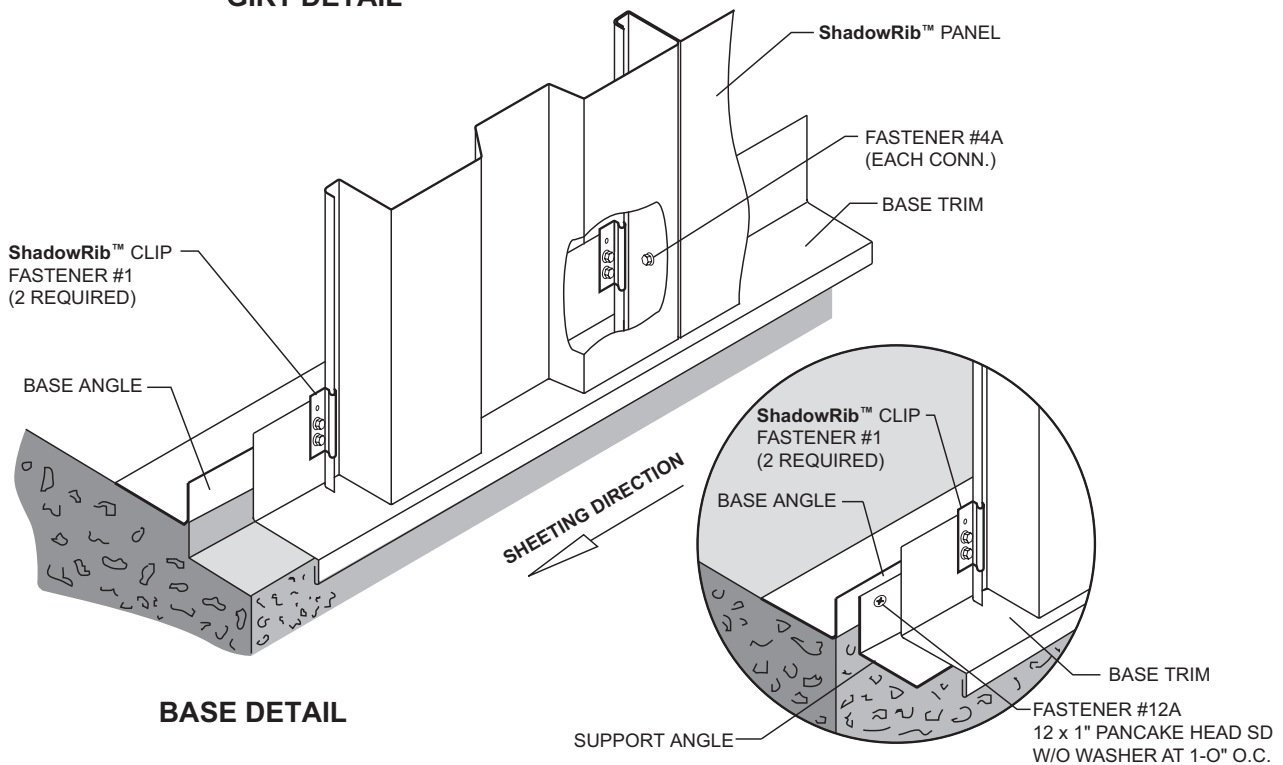

BASE DETAIL

ALTERNATE BASE

NOTES:

1. Attach base trim to base angle with Fastener #14A to hold in place until clips are installed (3 fasteners in each 10' piece).
2. For alternate base detail, support angle should be 1½" below floor level. Attach support angle to concrete 3' o.c.

ShadowRib™

INSTALLATION

PANEL CLIP ATTACHMENT (CONTINUED)

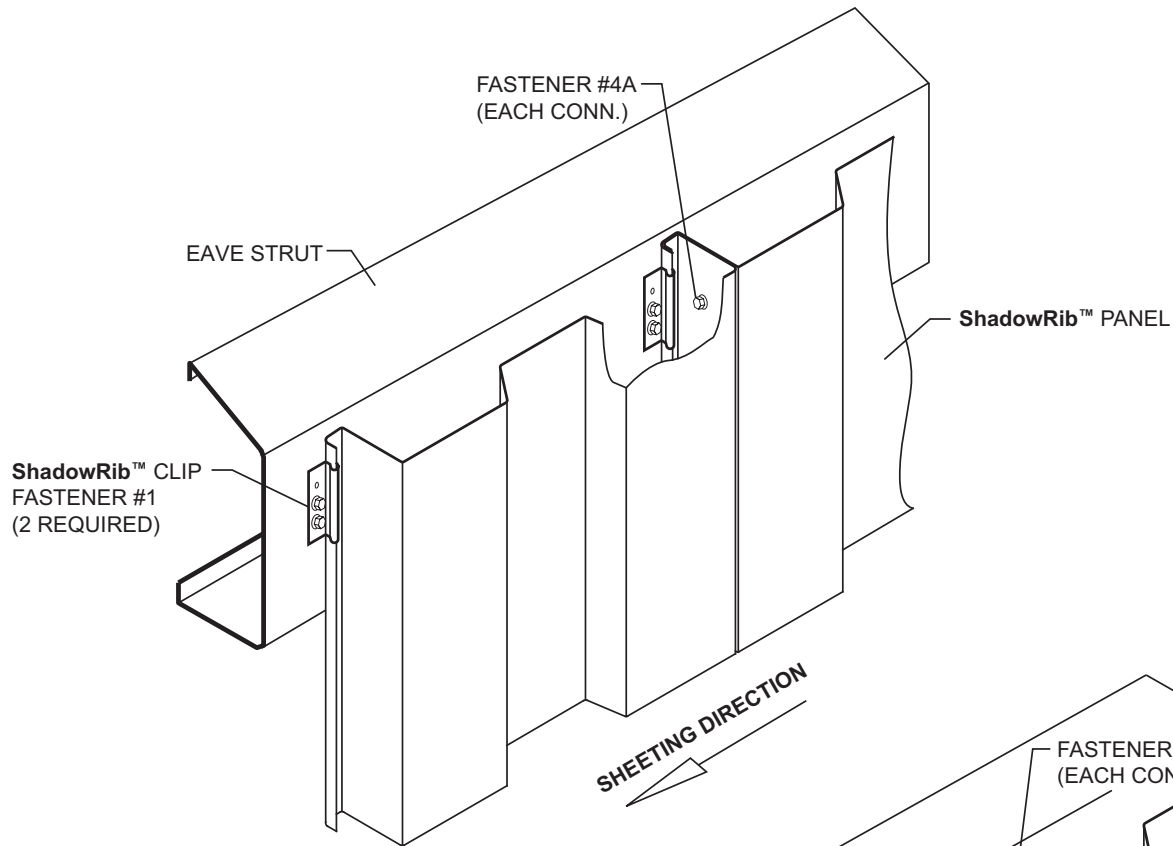

EAVE DETAIL

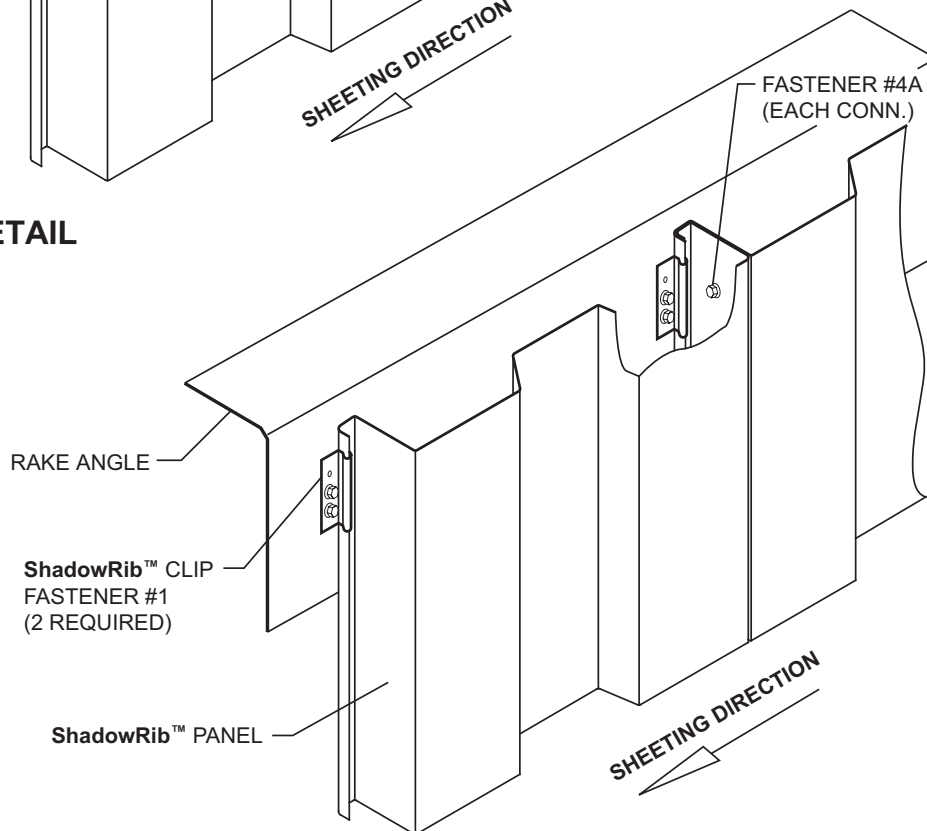

RAKE DETAIL

NOTES:

1. Do not install clips on eave strut or rake angle above the height of the wall panels.



Metal Roof and Wall Systems

Houston, TX 877/713-6224
Adel, GA 888/446-6224
Atlanta, GA 877/512-6224
Atwater, CA 800/829-9324
Dallas, TX 800/653-6224
Indianapolis, IN 800/735-6224
Jackson, MS 800/622-4136

Las Vegas, NV 877/713-6224
Lewisville, TX 877/713-6224
Lubbock, TX 800/758-6224
Mattoon, IL 888/885-0468
Memphis, TN 800/206-6224
Oklahoma City, OK 800/597-6224
Omaha, NE 800/458-6224

Phoenix, AZ 888/533-6224
Richmond, VA 800/729-6224
Rome, NY 800/559-6224
Salt Lake City, UT 800/874-2404
San Antonio, TX 800/598-6224

INSTALLATION

ShadowRib™

EAVE DETAILS

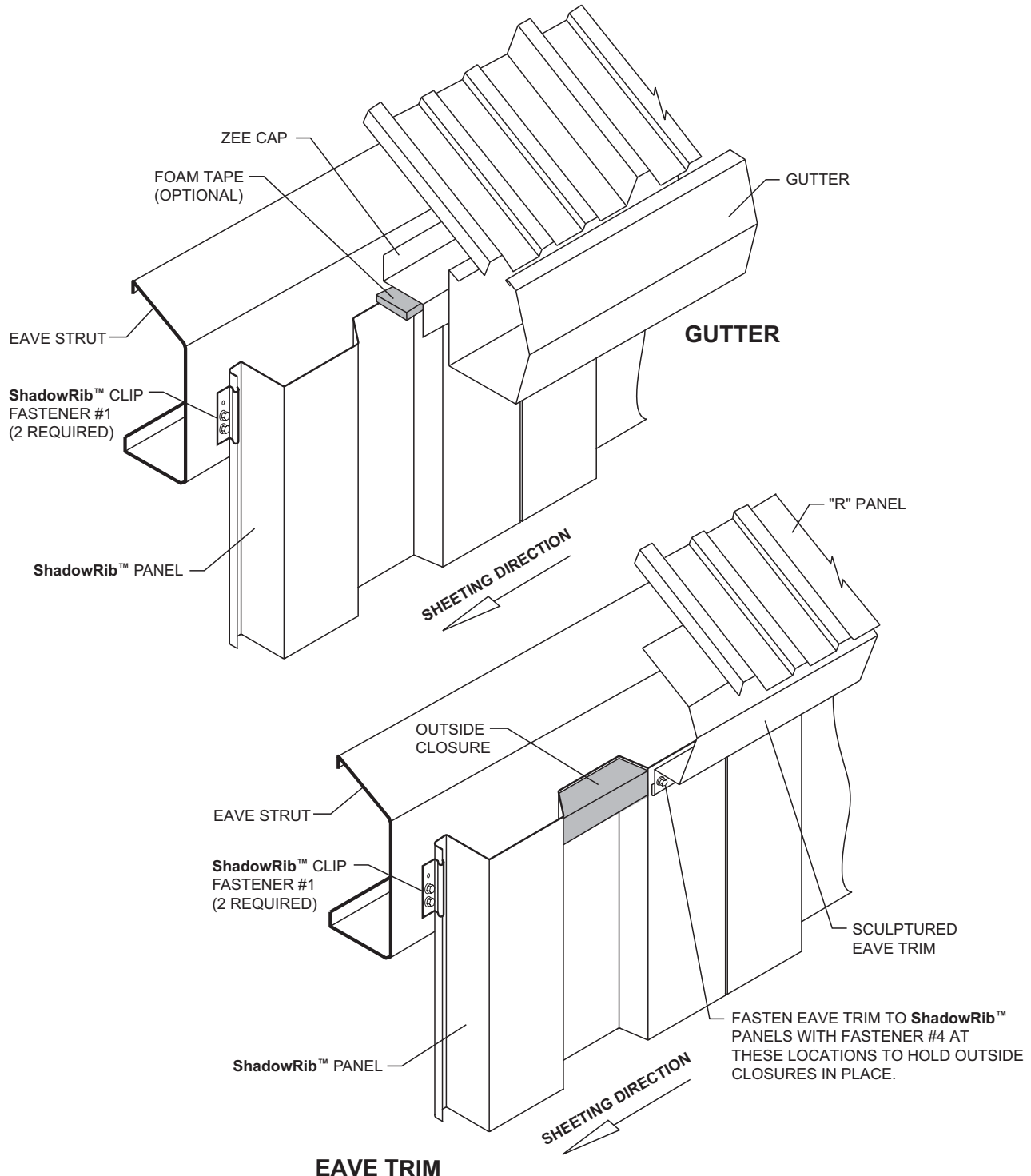

NOTES:

1. Details shown above to be used for exterior clip or interior fastener method (clip method shown).
2. Optional foam tape provided an airtight seal at the top of the panels.

ShadowRib™ INSTALLATION

RAKE DETAIL

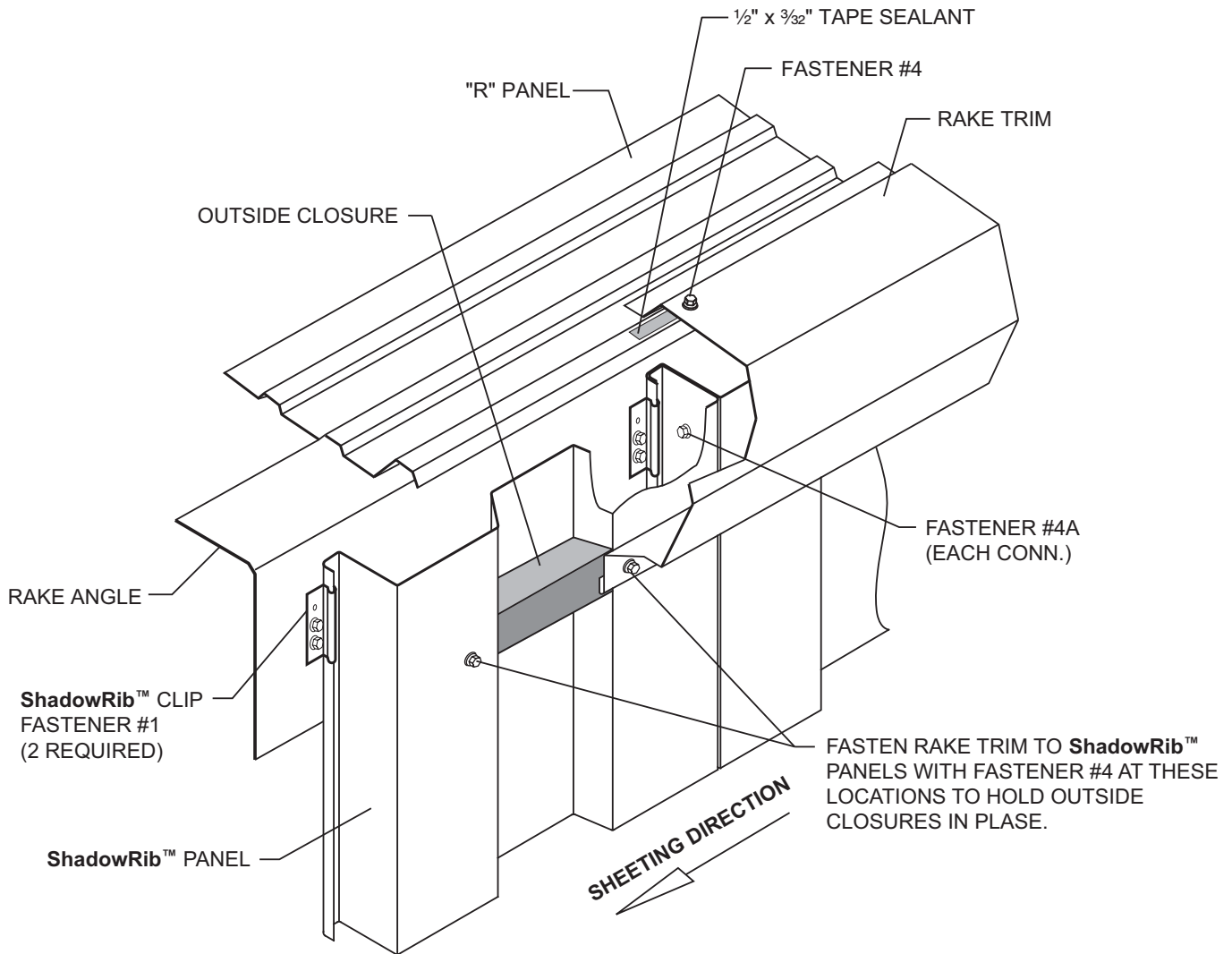

NOTES:

1. Details shown above to be used for exterior clip or interior fastener method (clip method shown).
2. Standard outside closures will fit properly on roof pitches of 2:12 or less.



Metal Roof and Wall Systems

Houston, TX 877/713-6224
Adel, GA 888/446-6224
Atlanta, GA 877/512-6224
Atwater, CA 800/829-9324
Dallas, TX 800/653-6224
Indianapolis, IN 800/735-6224
Jackson, MS 800/622-4136

Las Vegas, NV 877/713-6224
Lewisville, TX 877/713-6224
Lubbock, TX 800/758-6224
Mattoon, IL 888/885-0468
Memphis, TN 800/206-6224
Oklahoma City, OK 800/597-6224
Omaha, NE 800/458-6224

Phoenix, AZ 888/533-6224
Richmond, VA 800/729-6224
Rome, NY 800/559-6224
Salt Lake City, UT 800/874-2404
San Antonio, TX 800/598-6224

INSTALLATION

ShadowRib™

OUTSIDE CORNER

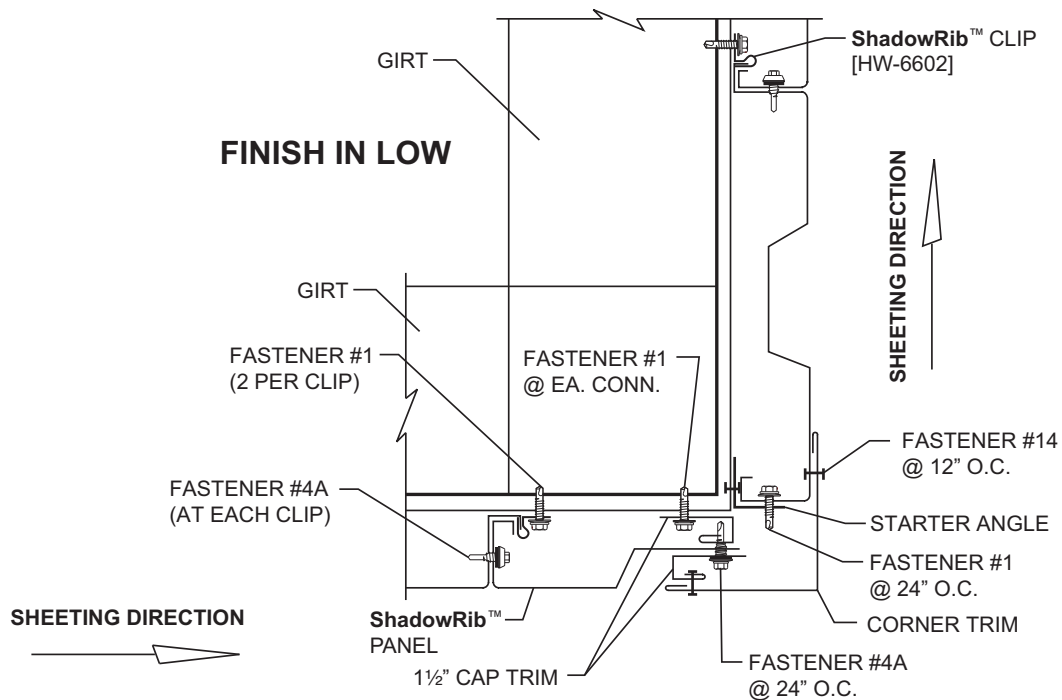
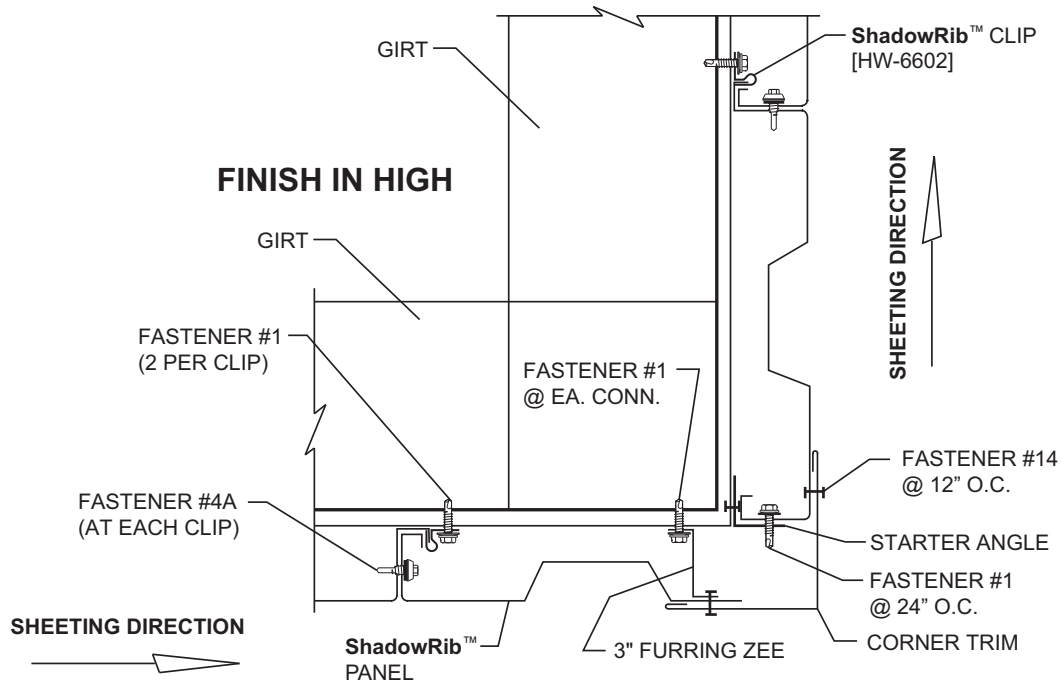

NOTES:

1. Details shown above to be used for exterior clip or interior fastener method (clip method shown).

ShadowRib™

INSTALLATION

INSIDE CORNER

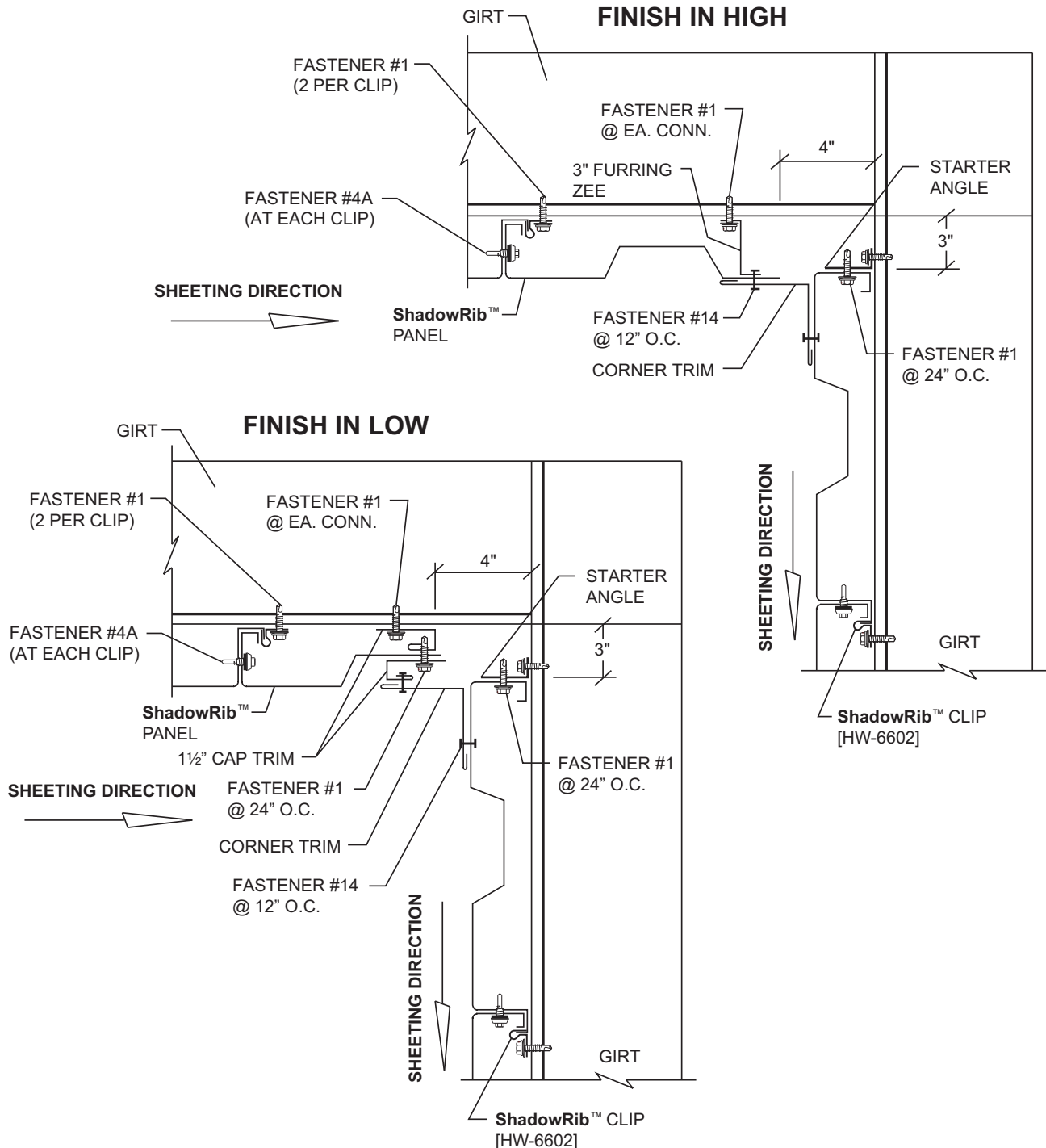

NOTES:

1. Details shown above to be used for exterior clip or interior fastener method (clip method shown).
2. When sheeting toward an inside corner, stop the last panel 4" from the steel line. When sheeting away from an inside corner, start the first panel 3" from the steel line.



Metal Roof and Wall Systems

Houston, TX 877/713-6224
Adel, GA 888/446-6224
Atlanta, GA 877/512-6224
Atwater, CA 800/829-9324
Dallas, TX 800/653-6224
Indianapolis, IN 800/735-6224
Jackson, MS 800/622-4136

Las Vegas, NV 877/713-6224
Lewisville, TX 877/713-6224
Lubbock, TX 800/758-6224
Mattoon, IL 888/885-0468
Memphis, TN 800/206-6224
Oklahoma City, OK 800/597-6224
Omaha, NE 800/458-6224

Phoenix, AZ 888/533-6224
Richmond, VA 800/729-6224
Rome, NY 800/559-6224
Salt Lake City, UT 800/874-2404
San Antonio, TX 800/598-6224

INSTALLATION

ShadowRib™

DETAILS AT OVERHED DOORS

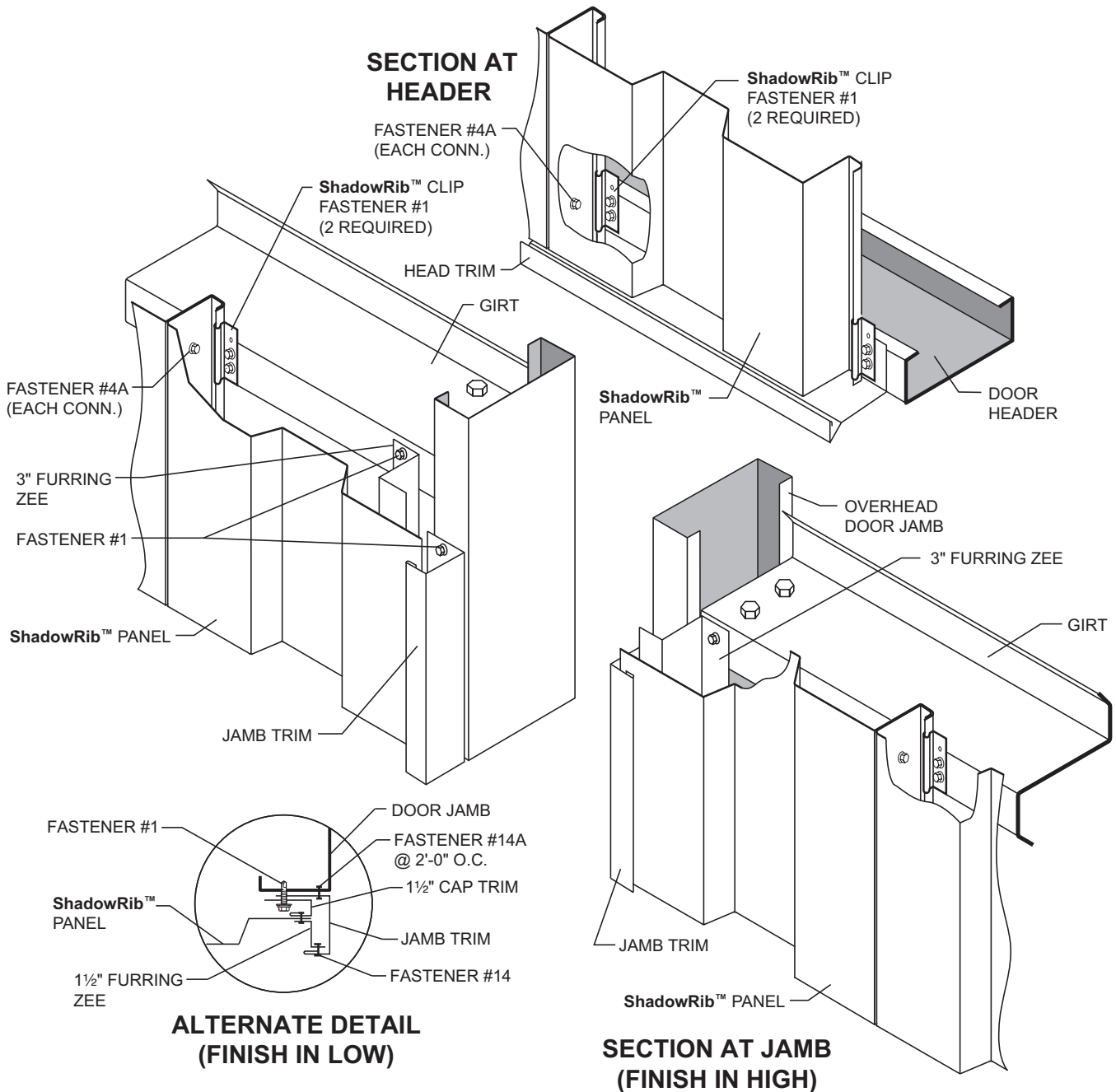

NOTES:

1. Seal the bottom of all panels above the overhead door inside the head trim with urethane sealant
2. The first panel cut for an overhead door will require attachment to the building from the inside.
3. Top of jamb trim must be mitered to fit slope of head trim.

ShadowRib™

INSTALLATION

DETAILS AT WALK DOORS

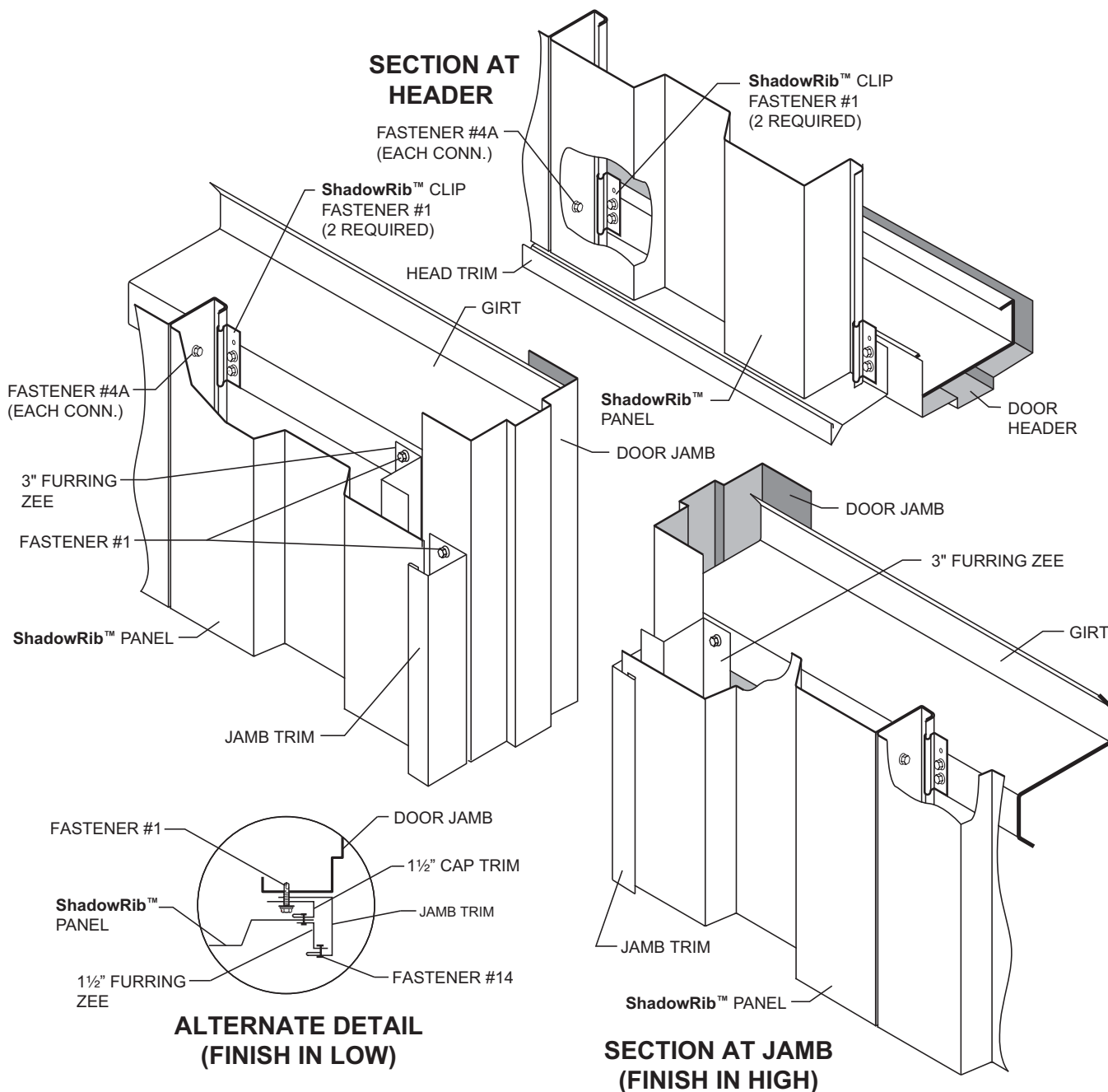

NOTES:

1. Seal the bottom of all panels above the walk door inside the head trim with urethane sealant.
2. The first panel cut for a walk door will require attachment to the building from the inside.
3. Top of jamb trim must be mitered to fit slope of head trim.



Metal Roof and Wall Systems

Houston, TX 877/713-6224
Adel, GA 888/446-6224
Atlanta, GA 877/512-6224
Atwater, CA 800/829-9324
Dallas, TX 800/653-6224
Indianapolis, IN 800/735-6224
Jackson, MS 800/622-4136

Las Vegas, NV 877/713-6224
Lewisville, TX 877/713-6224
Lubbock, TX 800/758-6224
Mattoon, IL 888/885-0468
Memphis, TN 800/206-6224
Oklahoma City, OK 800/597-6224
Omaha, NE 800/458-6224

Phoenix, AZ 888/533-6224
Richmond, VA 800/729-6224
Rome, NY 800/559-6224
Salt Lake City, UT 800/874-2404
San Antonio, TX 800/598-6224

INSTALLATION

ShadowRib™

DETAILS AT WINDOWS

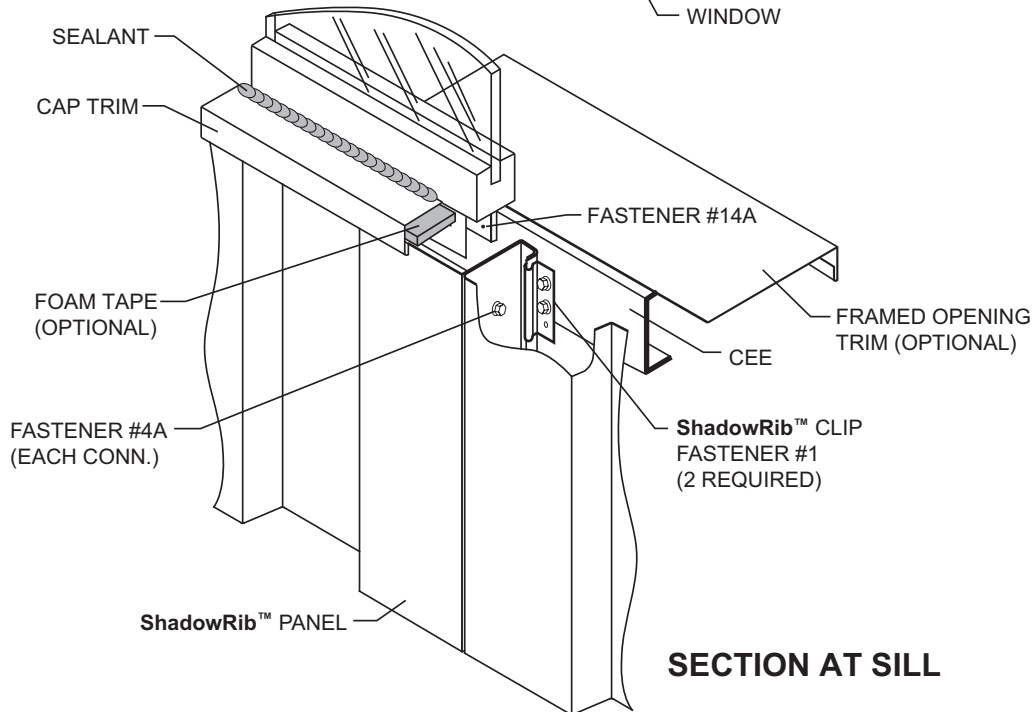
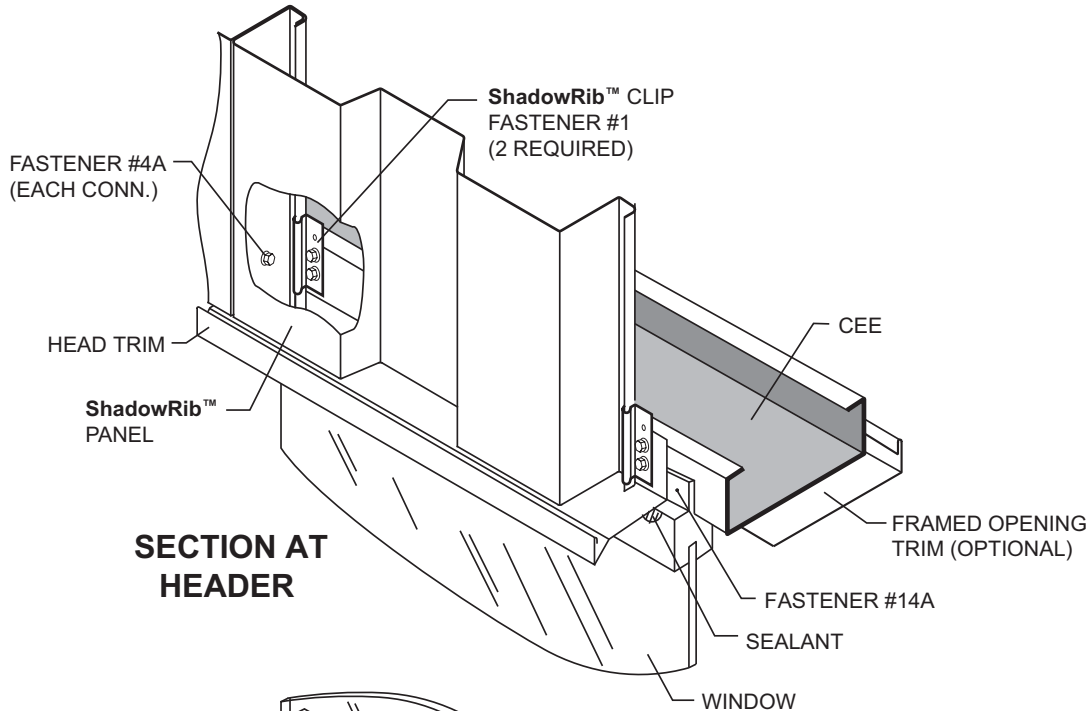

NOTES:

1. Details shown above to be used for exterior clip or interior fastener method (clip method shown).
2. Details shown utilize a straight fin window.
3. Foam tape can be applied to underside of sill trim to provide an airtight seal.

ShadowRib™

INSTALLATION

DETAILS AT WINDOWS (CONTINUED)

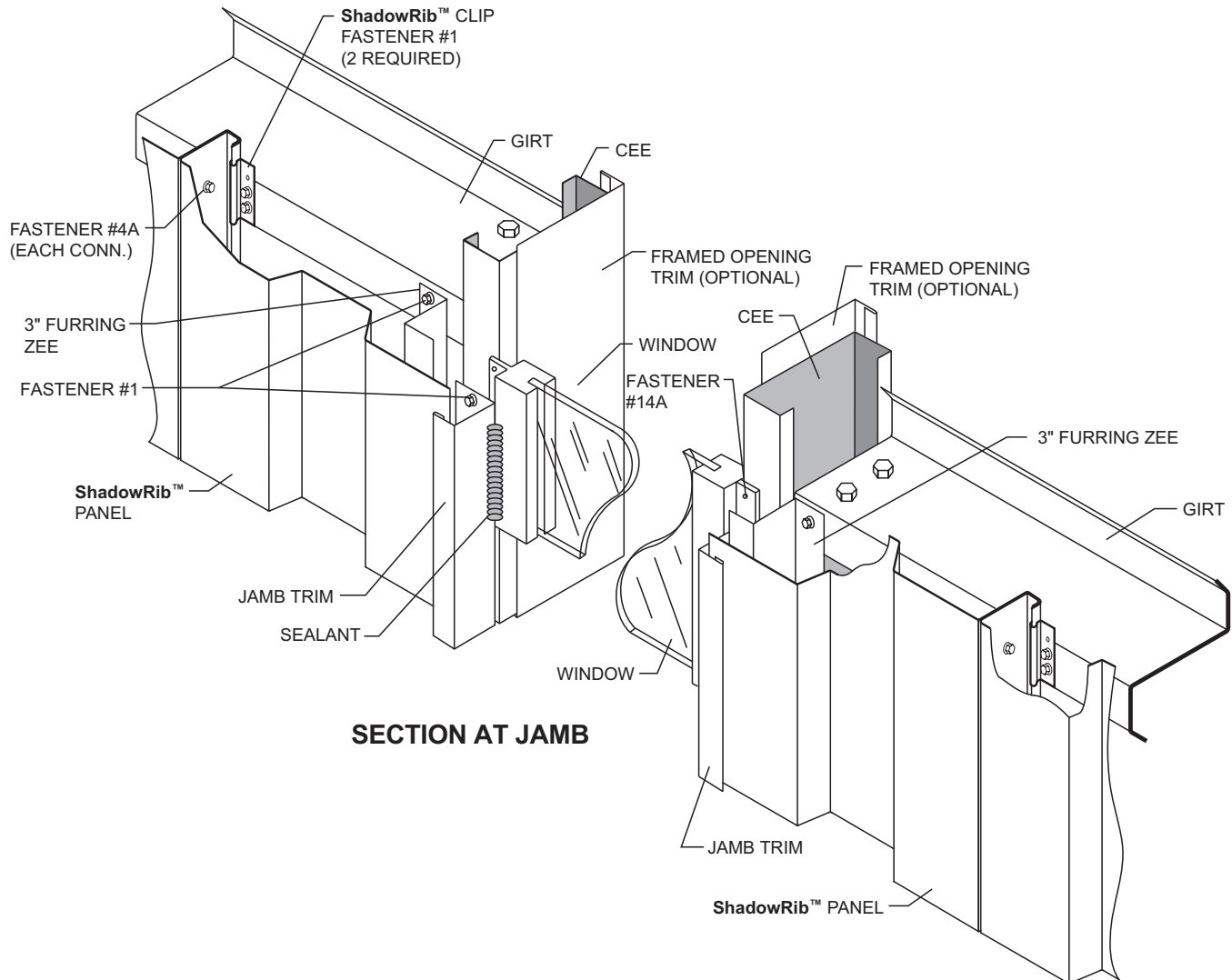

SECTION AT JAMB

NOTES:

1. All windows require a framed opening.
2. Install framed opening trim to top, bottom, and both sides of framed opening.
3. Install window from outside of building and attach to framed opening with Fastener #14A.
4. Install head trim at top and cap trim at bottom of window. Head trim and cap trim should be the width of the framed opening plus 4" in length.
5. Install jamb trim at both sides of the window. Jamb trim will fit inside of head trim and sill trim. Top of jamb trim must be mitered to fit slope of head trim.
6. Seal the bottom of all panels above the walk door inside the head trim with urethane sealant.
7. Seal window frame to trim on all four sides with urethane sealant.



Metal Roof and Wall Systems

Houston, TX 877/713-6224
Adel, GA 888/446-6224
Atlanta, GA 877/512-6224
Atwater, CA 800/829-9324
Dallas, TX 800/653-6224
Indianapolis, IN 800/735-6224
Jackson, MS 800/622-4136

Las Vegas, NV 877/713-6224
Lewisville, TX 877/713-6224
Lubbock, TX 800/758-6224
Mattoon, IL 888/885-0468
Memphis, TN 800/206-6224
Oklahoma City, OK 800/597-6224
Omaha, NE 800/458-6224

Phoenix, AZ 888/533-6224
Richmond, VA 800/729-6224
Rome, NY 800/559-6224
Salt Lake City, UT 800/874-2404
San Antonio, TX 800/598-6224

INSTALLATION

ShadowRib™

DETAIL AT WALL SPLICE

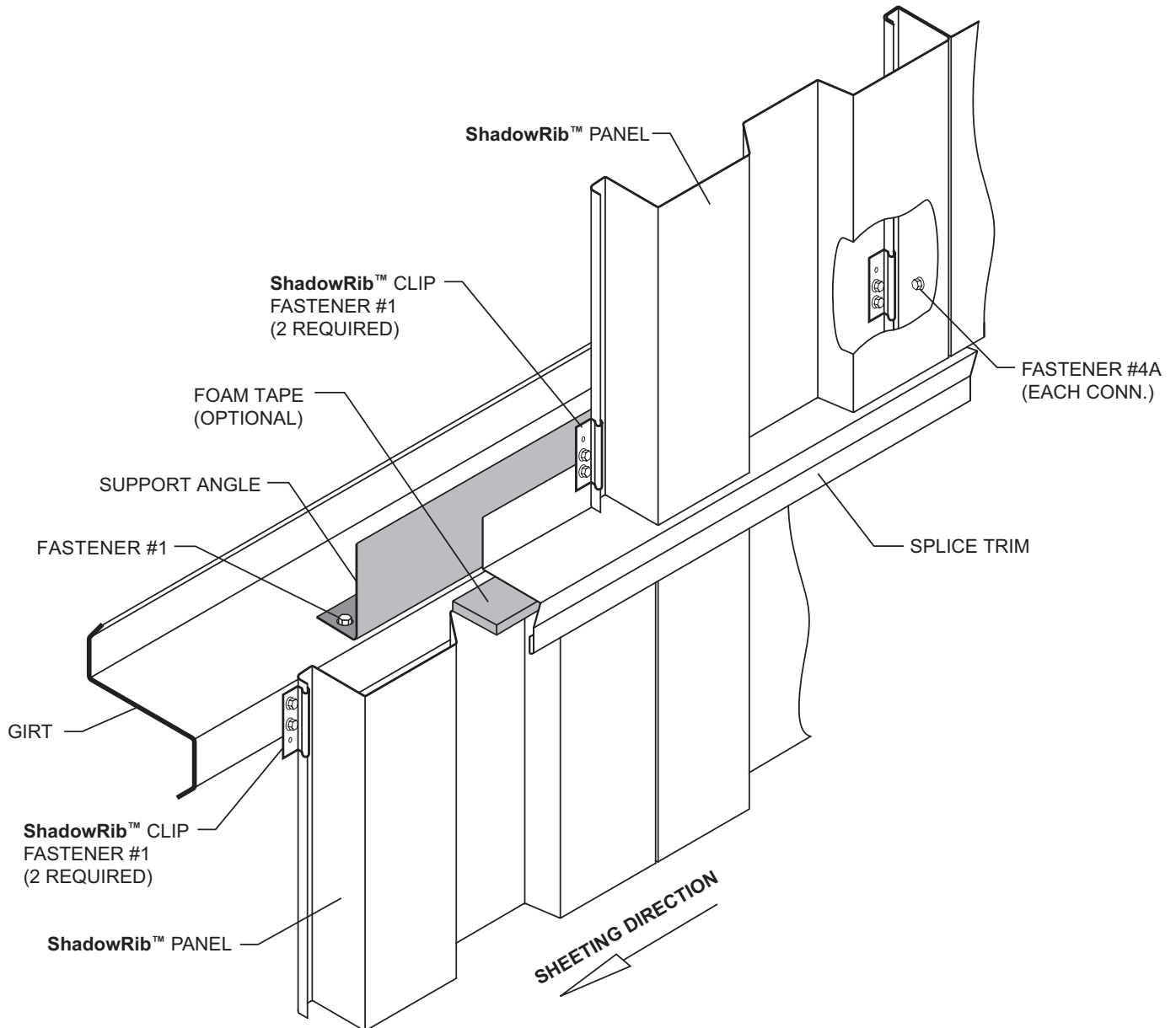

NOTES:

1. Details shown above to be used for exterior clip or interior fastener method (clip method shown).
2. Fasten support angle to girt with Fastener #1 at 1' o.c.
3. Do not install clips to girt higher than the top of the panels.
4. Foam tape can be applied to underside of sill trim to provide an airtight seal.

Houston, TX 877/713-6224
Adel, GA 888/446-6224
Atlanta, GA 877/512-6224
Atwater, CA 800/829-9324
Dallas, TX 800/653-6224
Indianapolis, IN 800/735-6224
Jackson, MS 800/622-4136

Las Vegas, NV 877/713-6224
Lewisville, TX 877/713-6224
Lubbock, TX 800/758-6224
Mattoon, IL 888/885-0468
Memphis, TN 800/206-6224
Oklahoma City, OK 800/597-6224
Omaha, NE 800/458-6224

Phoenix, AZ 888/533-6224
Richmond, VA 800/729-6224
Rome, NY 800/559-6224
Salt Lake City, UT 800/874-2404
San Antonio, TX 800/598-6224



Metal Roof and Wall Systems

NOTES



Metal Roof and Wall Systems

For the most current information available, visit our Web site at www.mbc.com

Houston, TX

14031 West Hardy
Houston, TX 77238
877/713-6224

Adel, GA

1601 Rogers Road
Adel, GA 31620
888/446-6224

Atlanta, GA

2280 Monier Avenue
Atlanta, GA 30336
877/512-6224

Atwater, CA

550 Industry Way
Atwater, CA 95301
800/829-9324

Dallas, TX

1804 Jack McKay Blvd.
Ennis, TX 75120
800/653-6224

Indianapolis, IN

1780 McCall Drive
Shelbyville, IN 46176
800/735-6224

Jackson, MS

201 Apache Drive
Jackson, MS 39272
800/622-4136

Las Vegas, NV

4700 Engineers Way, #103
N. Las Vegas, NV 89081
877/713-6224

Lewisville, TX

1497 N Kealy
Lewisville, TX 75057
877/713-6224

Lubbock, TX

5711 East FM-40
Lubbock, TX 79408
800/758-6224

Mattoon, IL

1509 Dewitt Ave E.
Mattoon, IL 61938
888/885-0468

Memphis, TN

300 Highway 51 North
Hernando, MS 38632
800/206-6224

Oklahoma City, OK

7000 S. Eastern Avenue
Oklahoma City, OK 73143
800/597-6224

Omaha, NE

1011 Ellison Avenue
Omaha, NE 68110
800/458-6224

Phoenix, AZ

660 South 91st Avenue
Tolleson, AZ 85353
888/533-6224

Richmond, VA

1703 Ruffin Mill Road
Colonial Heights, VA 23834
800/729-6224

Rome, NY

6168 State Route 233
Rome, NY 13442
800/559-6224

Salt Lake City, UT

1155 West 2300 North
Salt Lake City, UT 84116
800/874-2404

San Antonio, TX

8677 I-10 East
Converse, TX 78109
800/598-6224

